



BLUE BRUTE™ /
BIG BLUE™ / ULTRA BLUE™

AWWA C900/C905/C909 ASTM F1483

INSTALLATION GUIDE



*Building essentials
for a better tomorrow™*

 **WARNING**

RUPTURE HAZARD

IMPROPER INSTALLATION OR MISUSE OF TAPPING TOOLS MAY CAUSE PIPES UNDER HIGH PRESSURE TO RUPTURE AND RESULT IN HIGH VELOCITY AIRBORNE FRAGMENTATION LEADING TO SERIOUS INJURIES AND/OR DEATH.

• **BEFORE AND DURING INSTALLATION, ALWAYS:**

- CONSULT AND FOLLOW THE FULL VERSION OF THE PRODUCT INSTALLATION GUIDE
- CLOSELY FOLLOW JOB SPECIFICATIONS
- USE PROTECTIVE GEAR AND EQUIPMENT

• **BEFORE AND DURING TAPPING, ALWAYS:**

- CONSULT AND FOLLOW UNI-BELL® PUBLICATION UNI-PUB-08-07, "TAPPING GUIDE FOR PVC PRESSURE PIPE."
- USE THE CORRECT TAPPING TOOLS
- BLEED AIR FROM PIPES AT HIGH SPOT BEFORE TAPPING
- USE PROTECTIVE GEAR AND EQUIPMENT

PLEASE CONTACT JM EAGLE™ PRODUCT ASSURANCE AT (800) 621-4404 TO OBTAIN FULL VERSION OF THE APPROPRIATE INSTALLATION GUIDE OR FOR FURTHER ASSISTANCE.

BLUE BRUTE™ / BIG BLUE™ /ULTRA BLUE™

CONTENTS

1.0	RECEIVING AND HANDLING PIPE SHIPMENTS	8
1.1	INSPECTION	8
1.2	UNLOADING	9
1.3	COLD WEATHER HANDLING	11
1.4	STOCKPILES	11
1.5	GASKET CARE	12
1.6	LOADING TRANSFER TRUCKS	12
1.7	DISTRIBUTING ALONG THE TRENCH	13
2.0	TRENCH CONSTRUCTION	13
2.1	WORKING AHEAD OF THE PIPE LAYING CREW	13
2.2	CURVES IN THE TRENCH	14
2.2.1	BLUE BRUTE™ AWWA C900 AND ULTRA BLUE™ AWWA C909 (4"-16")	14
2.2.2	BIG BLUE™ AWWA C905 (14"-48")	15
2.3	TRENCH WIDTHS	16
2.4	TRENCH DEPTHS	17
2.5	PLANNING FOR THRUSTING	17
2.6	PREPARATION OF TRENCH BOTTOM	18
2.7	CASINGS	18
2.7.1	PLACEMENT OF CASINGS	18
2.7.2	PULLING THE PIPE	19

2.7.3	CLOSURE OF CASING AFTER PIPE INSTALLATION	21
3.0	PIPELINE CONSTRUCTION	23
3.1	INSPECTION	23
3.2	LOWERING PIPE AND ACCESSORIES INTO TRENCH	23
3.3	ASSEMBLY OF JM EAGLE™ PVC PIPE	24
3.4	ASSEMBLY INSTRUCTIONS	24
3.5	CUTTING	27
3.6	BEVELING	28
3.7	LOCATING REFERENCE MARK	28
3.8	ASSEMBLY AT FITTINGS AND ADAPTORS	28
3.9	THRUST BLOCKING AND ANCHORAGE AT FITTINGS	29
3.9.1	DETERMINING SIZE AND TYPE OF THRUST BLOCKING	29
3.9.2	UPWARD THRUSTS AT FITTINGS	32
3.9.3	ANCHORAGE OF PIPE ON SLOPES	32
3.9.4	ANCHORAGE OF VALVES IN THE LINE	33
3.9.5	CONSTRUCTION OF THRUST BACKING	33
3.10	INSTALLATION AT HYDRANTS	33
3.11	THRUST-RESTRAINT JOINTS	34
3.12	SERVICE CONNECTIONS	35
3.12.1	DIRECT TAPS, SADDLES, AND VALVES	35
4.0	PIPE EMBEDMENT	35
4.1	BEDDING	36
4.2	BACKFILLING AND TAMPING	36
4.2.1	HAUNCHING AND INITIAL BACKFILL	36
4.3	COMPLETING THE BACKFILL	38
4.3.1	FINAL BACKFILL	38
4.4	COMPACTION METHODS	39

4.4.1	TAMPING BARS	39
4.4.2	MECHANICAL TAMPERS	40
4.4.3	FLOOD OR WATER TAMPING	40
4.4.4	WATER-JETTING	41
4.4.5	SHEETING AND TRENCH BOXES	41
5.0	PIPE TESTING AND REPAIR	41
5.1	PIPE DEFLECTION	41
5.1.1	DEFLECTION TESTING	42
5.2	TESTING WATER PIPE	42
5.2.1	FILLING THE LINE	43
5.2.2	RELIEVING AIR FROM THE LINE	45
5.3	PRESSURE-STRENGTH TESTS	45
5.4	MAKING LEAKAGE TESTS	46
5.5	MAKING REPAIRS TO DAMAGED PIPELINES	48
	APPENDIX 1	49

THE PHYSICAL (OR CHEMICAL) PROPERTIES OF JM EAGLE™ BLUE BRUTE™ PVC C.I.O.D. DISTRIBUTION PIPE (AWWA C900), BIG BLUE™ PVC C.I.O.D. TRANSMISSION PIPE (AWWA C905), ULTRA BLUE™ PVC C.I.O.D. DISTRIBUTION PIPE (AWWA C909), AND ULTRA BLUE™ PVC I.P.S. DISTRIBUTION PIPE (ASTM F1483) PRESENTED IN THIS BOOKLET, REPRESENT TYPICAL AVERAGE VALUES OBTAINED IN ACCORDANCE WITH ACCEPTED TEST METHODS AND ARE SUBJECT TO NORMAL MANUFACTURING VARIATIONS. THEY ARE SUPPLIED AS A TECHNICAL SERVICE AND ARE SUBJECT TO CHANGE WITHOUT NOTICE. CHECK WITH JM EAGLE™ PRODUCT ASSURANCE TO ENSURE CURRENT INFORMATION.

HOW THIS GUIDE CAN HELP YOU

This booklet was written especially for the installer and those who direct actual handling and installation of JM Eagle™ PVC Blue Brute™, Big Blue™, and Ultra Blue™ pipe. This guide should be used in conjunction with the following industry accepted installation and testing practices which are applicable. This document should not be considered a full guide or manual in lieu of:

1. ASTM D2774-04 (or later) "Underground Installation of Thermoplastic Pressure Piping."
2. ASTM F690-86 (2003) (or later) "Underground Installation of Thermoplastic Pressure Piping Irrigation Systems."
3. ASTM F1668-96 (2002) (or later) "Construction of Procedures for Buried Plastic Pipe."
4. ASTM F645-04 (or later) "Selection, Design, and Installation of Thermoplastic Water-Pressure Piping Systems."
5. ASTM D2321-05 (or later) "Underground Installation of Thermoplastic Pipe for Sewers and Other Gravity-Flow Applications."
6. ASTM F1417-92 (2005) (or later) "Installation Acceptance of Plastic Gravity Sewer Lines Using Low-Pressure Air."
7. AWWA C605 "Underground Installation of Polyvinyl Chloride (PVC) Pressure Pipe and Fittings for Water."

8. AWWA C651 “Disinfecting Water Mains.”
9. AWWA M23 “PVC Pipe – Design and Installation.”
10. Uni-Bell® UNI-PUB-09 “Installation Guide for PVC Pressure Pipe.”
11. Uni-Bell® UNI-B-6 “Recommended Practice for Low-Pressure Air Testing of Installed Sewer Pipe.”
12. Uni-Bell® UNI-PUB-06 “Installation Guide for PVC Solid-Wall Sewer Pipe (4-15 Inch).”
13. Uni-Bell® UNI-TR-1 “Deflection: The Pipe/Soil Mechanism.”
14. Uni-Bell® UNI-TR-6 “PVC Force Main Design.”
15. Uni-Bell® UNI-TR-7 “Thermoplastic Pressure Pipe Design and Selection.”

This guide is meant as an explanatory supplement to the materials above on how to install JM Eagle™ PVC Blue Brute™, Big Blue™, and Ultra Blue™ pipe under normal conditions so as to comply with Standard JM Eagle™ Laying Specifications. Any discrepancies between the above standards and the written information contained herein, should be brought to the attention of JM Eagle™ Product Assurance immediately for resolution by JM Eagle™, prior to any actions by either contractor, engineer, or municipality.

This guide is not intended to supply design information nor to assume the responsibility of the engineer (or other customer representative) in establishing procedures best suited to individual job conditions so as to attain satisfactory performance.

Engineers, superintendents, contractors, foremen, and laying crews will find much to guide them in the following specifications. This booklet will also be of help in determining pipe needs when ordering.

WARRANTY

J-M Manufacturing Company Inc. (JM Eagle™) warrants that its standard polyvinyl chloride (PVC), polyethylene (PE), conduit/plumbing/solvent weld and Acrylonitrile-Butadiene-Styrene (ABS) pipe products (“Products”) are manufactured in accordance with applicable industry specifications referenced on the Product and are free from defects in workmanship and materials. Every claim under this warranty shall be void unless in writing and received by JM Eagle™ within 30 days of the date the defect was discovered, and within one year of the date of shipment from the JM Eagle™ plant. Claims for Product appearance defects, such as sun-bleached pipe etc., however, must be made within 30 days of the date of the shipment from the JM Eagle™ plant. This warranty specifically excludes any Products allowed to become sun-bleached after shipment from the JM Eagle™ plant. Proof of purchase with the date thereof must be presented to the satisfaction of JM Eagle™, with any claim made pursuant to this warranty. JM Eagle™ must first be given an opportunity to inspect the alleged defective Products in order to determine if it meets applicable industry standards, if the handling and installation have been satisfactorily performed in accordance with JM Eagle™ recommended practices and if operating conditions are within standards. Written permission and/or a Return Goods Authorization (RGA) must be obtained along with instructions for return shipment to JM Eagle™ of any Products claimed to be defective.

The limited and exclusive remedy for breach of this Limited Warranty shall be, at JM Eagle’s sole discretion, the replacement of the same type, size and like quantity of non-defective Product, or credits, offsets or combination of thereof, for the wholesale purchase price of the defective unit.

This Limited Warranty does not apply for any Product failures caused by user’s flawed designs or specifications, unsatisfactory applications, improper installations, use in conjunction with incompatible materials, contact with aggressive chemical agents, freezing or overheating of liquids in the Product, and any other misuse causes not listed here. This Limited Warranty also excludes failure or damage caused by fire stopping materials, tread sealants, plasticized vinyl products or damage caused by the fault or negligence of anyone other than JM Eagle™, or any other act or event beyond the control of JM Eagle™.

JM Eagle's liability shall not, at any time, exceed the actual wholesale purchase price of the Product. The warranties in this document are the only warranties applicable to the Product and there are no other warranties, expressed or implied. This Limited Warranty specifically excludes any liability for general damages, consequential or incidental damages, including without limitation, costs incurred from removal, reinstallation, or other expenses resulting from any defect. IMPLIED WARRANTIES OF MERCHANTABILITY OR FITNESS FOR A PARTICULAR PURPOSE ARE SPECIFICALLY DISCLAIMED AND JM Eagle™ SHALL NOT BE LIABLE IN THIS RESPECT NOTWITHSTANDING JM Eagle's ACTUAL KNOWLEDGE OF THE PRODUCT'S INTENDED USE.

JM Eagle's Products should be used in accordance with standards set forth by local plumbing and building laws, codes or regulations and the applicable standards. Failure to adhere to these standards shall void this Limited Warranty. Products sold by JM Eagle™ that are manufactured by others are warranted only to the extent and limits of the warranty of the manufacturer. No statement, conduct or description by JM Eagle™ or its representative, in addition to or beyond this Limited Warranty, shall constitute a warranty. This Limited Warranty may only be modified in writing signed by an officer of JM Eagle™.

1.0 RECEIVING AND HANDLING PIPE SHIPMENTS



Figure 1

1.1 INSPECTION

Each pipe shipment shall be inspected with care upon arrival. Each pipe shipment is carefully loaded at the factory using methods acceptable to the carrier. The carrier is then responsible for delivering the pipe as received from JM Eagle™. All shipments include an adequate amount of lubricant for the pipe and a short form installation guide. IT IS THE RESPONSIBILITY OF THE RECEIVER TO MAKE CERTAIN THERE HAS BEEN NO LOSS OR DAMAGE (including smoke) UPON ARRIVAL.

Check the materials, pipe, gaskets and fittings received against the bill of lading (tally sheet that accompanies every shipment) in accordance with the general guidelines below, reporting any error or damage to the transportation company representative and have proper notation made on the delivery receipt and signed by the driver. Present the claim in accordance with the carrier's instructions. Do not dispose of any damaged material. The carrier will advise you of the procedure to follow in order to procure samples and report the incident.

1. MAKE OVERALL EXAMINATION OF THE LOAD. If the load is intact, ordinary inspection while unloading should be enough to make sure the pipe has arrived in good condition.
2. IF LOAD HAS SHIFTED OR SHOWS ROUGH TREATMENT, THEN EACH PIECE MUST BE CAREFULLY INSPECTED FOR DAMAGE.

3. CHECK THE TOTAL QUANTITIES OF EACH ITEM AGAINST THE TALLY SHEET (pipe, fittings, lubricant, etc.)
4. ANY DAMAGED OR MISSING ITEMS MUST BE NOTED ON THE DELIVERY RECEIPT AND RETURNED TO THE TRANSPORTATION COMPANY.
5. NOTIFY CARRIER IMMEDIATELY AND MAKE CLAIM IN ACCORDANCE WITH THEIR INSTRUCTIONS.
6. DO NOT DISPOSE OF ANY DAMAGED MATERIAL. Carrier will notify you of the procedure to follow.
7. SHORTAGES AND DAMAGED MATERIALS ARE NOT AUTOMATICALLY RESHIPPED. If replacement material is needed, reorder through your distributor and make them aware of the claim.

1.2 UNLOADING



Figure 2

JM Eagle™ Blue Brute™, Big Blue™ and Ultra Blue™ Pressure Pipe is lightweight and may be unloaded by 1. Hand, either by passing over the side or off the truck ends. Sliding one length on another is standard practice in unloading PVC pipe, but lengths in the bottom layer should be lifted off of the rough surface of the truck body to avoid abrasion. 2. Conventional forklift, for large orders of pipe, which are bundled in pallets. Care shall be exercised to avoid impact or contact between the forks and the pipe. The means by which JM Eagle™ PVC Blue Brute™, Big Blue™ and Ultra Blue™ Pressure Pipe is unloaded in the field is the decision and responsibility of the customer. Preferred unloading is in units using mechanical equipment such as forklifts, cranes, cherry pickers or front-end loaders with adequate forks, trained, competent

operators, and equipment rated to safely handle the load. When unloading units, the following instructions should be carefully followed. Remove only one unit at a time.

1. Remove restraints from the top unit loads. These may be either tie down straps, ropes, or chains with protection.
2. If there are boards across the top and down the sides of the load, which are not part of pipe packaging, remove them.
3. Use a forklift (or front-end loader equipped with forks) to remove each top unit one at a time from the truck. Remove back units first. Do not run the forks too far under the unit as fork ends striking adjacent units may cause damage, or push other unit off opposite side of truck. Do not let forks rub the underside of pipe to avoid abrasion.
4. If a forklift is not available, a spreader bar on top and nylon strips capable of handling the load, spaced approximately eight (8) feet apart looped under the unit may be used. Cables may also be cushioned with a rubber hose sleeve or other material to prevent abrasion of the pipe.
5. During the removal and handling be sure that the units do not strike anything. Severe impact could damage the pipe (particularly during cold weather).
6. DO NOT:
 - a. Handle units with chains or single cables.
 - b. Attach cables to unit frames for lifting.
7. Units should be stored and placed on level ground. Units should be protected by dunnage in the same way they were protected while loaded on the truck. The dunnage must support the weight of all units so that pipe lengths do not carry the weight of the unit loaded above them. Units should not be stacked more than two (2) high.
8. To unload lower units, repeat the above unloading process (items 1 through 7).

WARNING: PVC pipe, though lighter than other material, is still heavy and may be dangerous if not handled properly. Not adhering to the above instructions may result in serious injury to pipe, property, and/or persons. Do not stand or climb on units. Stand clear of pipe during unloading.

NOTICE: Pipe at the bottom of a stack may become out-of-round due to the weight of material above it. At normal application temperatures this corrects itself soon after the load is removed due to the property of elastic memory. Under freezing conditions this recovery to full initial roundness may take several hours.

1.3 COLD WEATHER HANDLING

As the temperature approaches and drops below freezing, the flexibility and impact resistance of PVC pipe is reduced. Extra care should be used in handling during cold weather to avoid any type of impact to the pipe to prevent damage.

1.4 STOCKPILES

Store pipe on a flat surface so as to support the barrel evenly, with bell ends overhanging. If mechanical equipment is being used for handling, the unit bearing pieces provide an excellent base. If unloading by hand, secure two timbers for a base. Set them on a flat area spaced the same as a factory load. Nail chock blocks at each end. Build up the stockpile in the same manner, as it was stacked for shipment, transferring dunnage and chock blocks from load to stockpile. Store random lengths separately where they will be readily available. Individual lengths of pipe should be stacked in piles no higher than five (5) feet.

It should be noted that when PVC pipe is stored outside and exposed to prolonged periods of sunlight, an obvious discoloration or UV degradation of pipe could occur. Based on the 24-month weathering study, the performance of PVC pipe was equally impressive. No significant changes in tensile strength at yield was observed. Reductions in impact strength were apparent after two years of exposure to weathering and ultra violet radiation. However, considering PVC pipe's high initial impact strength, the reductions were not significant enough to warrant concern. Pipe breakage due to impact loads encountered during normal handling and installation is not a problem with PVC pipe. This UV degradation does not continue after the pipe is removed from UV exposure.

A method of protecting pipe during long exposures (several months) to sunlight is to cover it with canvas or other opaque material. Clear plastic sheets are not satisfactory. Allow for adequate air circulation between the cover and the pipe. This will prevent heat build-up and possible dimensional distortion.

1.5 GASKET CARE

All JM Eagle™ PVC pipe is manufactured with factory installed gaskets. These gaskets cannot be easily removed or replaced outside of the factory. Keep them clean, away from oil, grease, excessive heat and electric motors, which produce ozone. It is advisable to keep gaskets protected from direct sunlight and temperature changes in order to avoid cracking in prolonged exposure for optimal performance. JM Eagle™ provides a gasket that is approved for water service with its standard product. Special gasket types may be available for applications where oil resistance is required. Be sure the correct ring is ordered. See [Section 3.4](#) for further information.

1.6 LOADING TRANSFER TRUCKS

Use trucks with long bodies so that pipe lengths do not over hang more than two (2) feet. Make certain truck bed is smooth, without cross-strips, bolt heads, or other protrusions that could damage the pipe.

Place the first layer carefully with the bell ends overhanging. Avoid sliding the pipe and abrading it. Subsequent layers can be slid into place. All bell ends should overhang the layer below.

Short body trucks may be used if fitted with racks that properly support the pipe in the horizontal position. The rack shall support the pipe with supports spaced every three (3) feet or less along the pipe lengths. Pad the contact areas to avoid damage to the pipe.

1.7 DISTRIBUTING ALONG THE TRENCH

In stringing out pipe, keep these points in mind:

1. Line pipe as near to the trench as possible to avoid excessive handling. (Bell direction has a negligible affect on flow and hydraulic coefficients.)
2. If the trench is open, it is advisable to string pipe on the side away from excavated earth wherever possible, so that the pipe can be moved easily to the edge of the trench for lowering into position.
3. If the trench is not yet open, find out which side the excavated earth will be thrown; then string out on the opposite side (leave room for the excavator).
4. Place the pipe so as to protect it from traffic and heavy equipment. Also, safeguard it from the effect of any blasting that may be done.

2.0 TRENCH CONSTRUCTION

2.1 WORKING AHEAD OF THE PIPE LAYING CREW

Where soil and ground water conditions permit, long stretches of trench can be opened ahead of pipe laying, so as to take full advantage of the easy handling and speed of assembly of JM Eagle™ PVC Blue Brute™, Big Blue™ and Ultra Blue™ pipe with elastomeric joints. However, for most jobs as a general rule, do not open the trench too far ahead of pipe laying. Avoiding these long stretches of opened trench may help with the economy of the project because:

1. It may reduce or even eliminate pumping or sheeting.
2. It minimizes the possibility of flooding the trench.
3. It reduces caving caused by ground water.
4. It helps avoid frozen trench bottom and backfill.
5. It reduces hazards to traffic and workmen.

On most jobs it will be desirable to keep excavating, pipe laying and backfilling close together.

2.2 CURVES IN THE TRENCH

2.2.1 BLUE BRUTE™ AWWA C900 (4 INCHES TO 12 INCHES) AND ULTRA BLUE™ AWWA C909 (6 INCHES TO 16 INCHES)

The trench may be curved to change direction or avoid obstructions within the limits of the curvature of the pipe as shown in [Table 1](#):

PIPE SIZE (inches)	MINIMUM RADIUS (feet)	OFFSET (in)
4	100	24.08
6	150	16.02
8	200	12.01
10	250	9.61
12	300	8.00

Table 1

* Offset based on 20 feet length of pipe forming a true arc.

The line may be assembled above ground, in a straight line, and then curved when laid in the trench. All curvature results from the bending of the pipe lengths. **The maximum angular deflection at the joint is 1 degree.** The approximate force per 20-foot length in pounds to accomplish these curvatures is shown in [Table 2](#) (based on DR):

PIPE SIZE (inches)	DR 25	DR 18	DR 14
4	16.36	21.62	26.32
6	47.21	60.85	74.25
8	102.77	135.79	165.29
10	185.35	245.54	299.27
12	309.09	407.09	498.65

Table 2

NOTICE: Mechanical means should not be employed to accomplish these radii. It is the intent that the workers should accomplish this manually in the trench. ON 4-INCH TO 12-INCH, THE CURVE CAN BE ACCOMPLISHED BY BENDING THE PIPE. TO AVOID OVER-STRESSING THE BELL AND TO PREVENT POSSIBLE BREAKAGE AND/OR LEAKS, THE MAXIMUM ANGULAR DEFLECTION IN THE JOINTS IS 1 DEGREE.

To avoid deflecting the joints while achieving curvature, it is recommended that the joints be sufficiently braced or backfilled and compacted to keep them stationary. Abrupt changes in direction shall be accomplished with fittings.

2.2.2 BIG BLUE™ AWWA C905 (14 INCHES TO 48 INCHES) AND ULTRA BLUE AWWA C909 (16 INCHES)

Since the moment of inertia of Big Blue™ Pressure Pipe is high, attempting to curve the pipe is extremely difficult. JM Eagle's recommendation for 14-inch through 48-inch-diameter Big Blue™ and 16-inch Ultra Blue™ is that the angular deflection at the joint is a maximum of 1.5 degrees. This will produce an offset in a 20-foot section of approximately 6.25 inches. Joint deflection is achieved after the joint is assembled in straight alignment and to the reference mark. The bell should be braced in order to allow the free end to move laterally under steady pressure using a pry bar or other suitable means. Care should be taken not to exceed the maximum deflection allowed or damage the pipe with the machinery used. The line may be assembled above ground, in a straight line then offset when laid in the trench, if necessary. Abrupt changes in direction shall be accomplished with fittings.

NOTICE: AVOID OVER-STRESSING THE BELL (over-inserting the joints, or exceeding the maximum deflection/curvature allowed) IN ORDER TO PREVENT POSSIBLE BREAKAGE AND/OR LEAKS.

2.3 TRENCH WIDTHS

Since JM Eagle™ PVC Blue Brute™, Big Blue™ and Ultra Blue™ Pressure Pipe can be assembled above ground and lowered into position, trench widths can be kept to a minimum. The trench width at the ground surface may vary with and depend upon depth, type of soils and position of surface structures. The minimum clear width of the trench, sheeted or unsheeted, measured at the spring-line of the pipe should be 1 foot greater than the outside diameter of the pipe. The maximum clear width of the trench at the top of the pipe should not exceed a width equal to the pipe outside diameter plus 2 feet. (See [Figure 3](#).) This spacing will allow for proper compacting of the backfill to provide necessary sidewall support. It will also allow assembly work in the trench, if desired. If the above defined trench widths must be exceeded or if the pipe is installed in a compacted embankment, pipe embedment should be compacted to a point of at least 2.5 pipe diameters from the pipe on both sides of the pipe or to the trench walls, whichever is less.

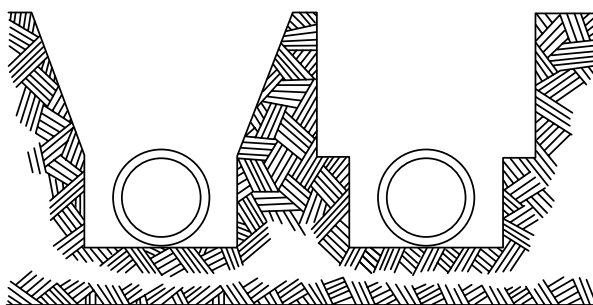

Figure 3

NOTICE: PVC pipe is a flexible pipe, so trench width and shape have little to no effect on loading experienced by the pipe, since the maximum load that may be carried by the pipe is that due to the column of soil directly above the pipe outside diameter. The trench width recommendations above help installers realize the economies that may result from installation of PVC pipe over other materials, while maintaining adequate control over backfilling, compaction and placement to limit long-term deflection.

2.4 TRENCH DEPTHS

Depth is governed by surface loads, earth loads and frost penetration. A minimum of 12 inches depth of cover is recommended where frost penetration need not be considered. Where frost is a factor, pipe should be buried 6 inches below the greatest recorded frost penetration. If the line will be drained and not used in winter, frost need not be considered.

Should unusual soil conditions and/or surface loads be anticipated and the engineer wants to calculate deflection when working with pressure pipes, “pipe stiffness” ($f/\Delta y$) can be found in [Table 3](#) below:

PIPE DR	STIFFNESS (psi)	PIPE DR	STIFFNESS (psi)
64	7	25	129
51	14	21	224
41	28	18	364
35	46	17	437
32.5	57	14	815
26	115	—	—

Table 3

For more information on deflection, see [Section 5.1](#).

2.5 PLANNING FOR THRUSTING

Fittings used for changes in direction and all in-line valves will require thrust blocking or restraints, which must be formed against a solid trench wall. Do not machine dig at these fitting areas because the excavator will usually dig too far and damage the bearing surface of the trench wall. A small amount of hand digging just behind the fitting location will ensure a solid trench wall for thrust block construction later on.

2.6 PREPARATION OF TRENCH BOTTOM

The trench bottom should be smooth and free from stones greater than 1.5 inches in diameter, large dirt clods, and any frozen material. Excavation at bells (bell holes) should be provided so that the pipe is uniformly supported along its length as seen in [Figure 4](#).



Figure 4

Generally, loose material left by the excavator on the trench bottom will be adequate for bedding the pipe barrel so that it is fully supported. Where the excavator cuts a very clean bottom, soft material can be shaved down from the sidewalls to provide needed bedding. If the trench bottom is rocky or hard, as in shale, place a 4-inch layer of selected backfill material to provide a cushion for the pipe. In rock excavation it is necessary that rock be removed and a bed of sand or selected backfill at least 4 inches deep be placed on the bottom of the trench to provide a cushion for the pipe. A pipeline of any material resting directly on rock, in the absence of a bedding cushion, is subject to breakage under the weight of the backfill load, surface load, or earth movements.

When an unstable trench bottom is encountered and, in the opinion of the engineer, it cannot support the pipe, an additional depth should be excavated and refilled to the pipe grade with material approved by the engineer.

Trenches can be dangerous, and the contractor has the responsibility of ensuring that all safety regulations and design requirements have been observed for the protection of the workers and the public.

2.7 CASINGS

2.7.1 PLACEMENT OF CASINGS

The placement of casings requires special equipment and skills. It is a specialized field of construction, to which some construction firms devote their entire efforts.

In the smaller diameters, the steel casing is usually placed progressively, following the boring equipment as it tunnels through the obstruction. The recommended practice is to use plain steel pipe (not corrugated) for the casing to facilitate movement of the PVC pipe through the casing with a minimum of resistance. For larger diameters, most of the casing construction is done by jacking the pipe from excavated pits. Where long casings are involved, numerous pits for jacking operations are required along the route. Regardless of the diameter, accuracy in alignment and grade of the casing pipe is very important in maintaining the established inverts.

2.7.2 PULLING THE PIPE

When PVC pipe is to be installed in casings under highways or railroad tracks, skids with rounded ends must be used to prevent the pipe and bells from snagging on the inside of the casing, and to keep the installed line from resting on the bells of the pipe. Skids shall be thick enough to allow clearance between the bells and the casing bottom. Normally two to four skids are only placed on the pipe spaced at 90 degrees as shown in [Figure 5](#). For pipe larger than 18 inches, six skids should be placed at 60 degrees apart.

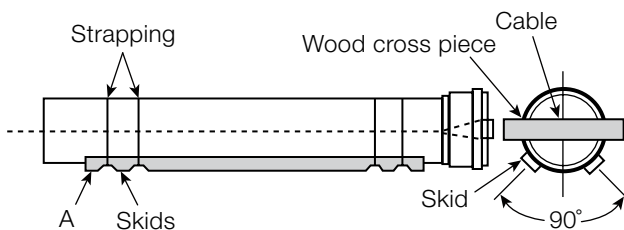

Figure 5

A cable is passed through the casing and the first pipe length is fastened to a suitable wood crosspiece at the end of the pipe. The cable is then pulled steadily by a winch, tractor or other method until about 2 feet of pipe is left projecting out of the casing for assembly of the next length. (If cable is pulled at an angle, make sure that the leading pipe end is protected from damage.) The cable is then passed through the next pipe and the two pipes are assembled. This operation is continued until the pipe is completely through the casing.

NOTICE: In order to prevent over-insertion of the pipe joint while installing it through casings, some method of restricting the movement between the assembled bell and spigot must be provided. Four such assemblies should be made at 90-degree spacing around the pipe bells. All “B” Skids must be tightly strapped to the pipe by metal strapping or similar material. Also, note that all skids should be notched and leveled so that they form a smooth, flat bottom. This is necessary so that no portion of the pipe is carrying the total load. An illustration of one proposed method is shown in [Figure 6](#).

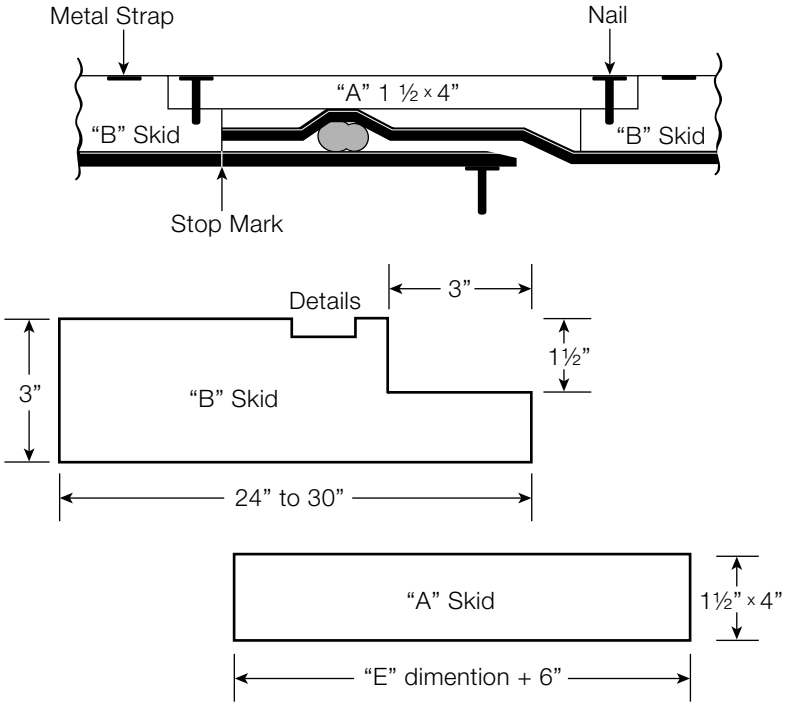

Figure 6

The inserted PVC pipelines should be circumferentially braced in the casing to prevent movement in any direction. In force sewer mains, movement can be caused by the thrust action generated by a slightly deflected joint. For gravity flow lines, movement of the inserted pipe may be caused by floatation from flooding of the annular spaces at each end of the casing. It is recommended that these spaces be sealed as described in [Section 2.7.3](#).

In some cases, small pipe in larger casings may require skids or positioning braces placed around the entire circumference of the pipe to keep the pipe in proper alignment in the casing. When pipe is pulled into a casing with a cable, the pipe may rotate, causing the skids and positioning braces to rotate from their entry position. Consequently, if a sufficient number, size and circumferential spacing of skids and braces are not employed, the bells cannot be kept from contacting the casing surfaces. Lubricating the casing or skids will make sliding easier. Depositing drilling mud or flax soap at the end of the casing can lubricate the casing. Then attach rags to the cable and pull them through so that they act as swabs or spreaders. A rope attached to the cable will make it easy to retrieve.

Petroleum products, such as oil and grease, should not be used as lubricants since prolonged exposure to these products is detrimental to the rubber gaskets used to seal the joints.

PVC pipe may also be pushed through the casing, using equipment, which will exert a constant and uniform force against the pipe end. To accomplish this, the pushing equipment must be firmly anchored and the joints sufficiently braced.

2.7.3 CLOSURE OF CASING AFTER PIPE INSTALLATION

Under no circumstances should the ends of the casing be closed or any material installed inside the casing until the completion of the pressure test and approved by the engineer. After testing, the ends of the casing should be sealed off.

A generally accepted practice is to sack the end of the casing, leaving an opening on the bottom. Sacking is to be placed between the PVC pipe and the casing except that the areas at the bottom between the skids are to be left open. This will keep backfill out of the casing, while allowing for drainage.

The casing should not be backfilled with sand unless specified by the engineer. When sand is used, drainage is obstructed and access to the interior of the casing is made more difficult. Also, if the sand is packed tightly, the load on the casing may be transferred to the PVC pipe, thus nullifying the purpose of the casing. Where backfilling of the annular space under and around the encased pipe is required, three-fourths of the distance to the top of the

casing should be filled with sand or other approved material. Again, the areas between the skids (under the pipe) should be left open for drainage. Using a hose line, sand can be forced into the casing with water under pressure. Care must be taken to avoid forcing too much water into the casing because of the possibility of floating the pipe. Floatation could result in uneven support for the encased pipeline if the skid system fails to prevent movement in all directions.

NOTICE: Under no circumstances should any blocks or spacers be wedged between the pipe and the top of the casing.

Pressure grouting when not strictly controlled can collapse PVC pipe. Grout pressures should not exceed the recommended grouting pressures given in *Table 10.1* of the 4th edition of the Handbook of PVC pipe. Pressure grouting is sometimes specified for filling in the annular space between the pipeline and the casing.

If pressure grouting is to be utilized, it will be necessary to arrange the skids and position braces on the pipe so as to accommodate a 2-inch grouting hose.

The recommended pressure grouting method is as follows:

1. Arrange the skids and position braces on the pipe as shown in [Figure 6](#). They will accommodate the grouting hose.
2. Secure the grouting hose to the leading end of the first pipe section before insertion begins.
3. Either push or pull the pipe into the casing, channeling the hose in place on the leading end of each succeeding section of pipe.
4. Cap or plug each end of the bore, leaving an air hole at the top of the low end and a hole at the top of the high end for the grouting hose to pass through.

Use a grout mixture in a ratio of four (4) parts cement to one (1) part sand, with sufficient water to yield a consistency of thick soup.

Start pumping very slowly. A sensitive pressure gauge should be mounted on the discharge outlet of the grouting machine. A pressure will develop equal to pressure needed to deliver the grout through the hose. After this pressure

is established, any increase in pressure by 2 or 3 psi will indicate a need to pull the grouting hose slightly until the pressure returns to the established average delivery pressure. It is essential that the pressure generated does not exceed 2 or 3 psi over the initial required delivery pressure. Continue this procedure until the bore is $\frac{3}{4}$ of the way full.

NOTICE: Wooden skids in backfill should have a long life. The life of the skids will be further extended if they are treated before backfilling. If there is to be no backfill, it is important that the skids be treated with a wood preservative. Functionally, it is not necessary to backfill around the pipe inside the casing with sand or any other material.

3.0 PIPELINE CONSTRUCTION

3.1 INSPECTION

Pipe and accessories should be inspected for defects and cleanliness prior to lowering into the trench. Any defective, damaged or unsound material should be repaired or replaced and foreign matter or dirt should be removed from the interior of the pipe and accessories before lowering into the trench.

3.2 LOWERING PIPE AND ACCESSORIES INTO TRENCH

All pipe, fittings, valves and accessories should be carefully lowered into the trench using suitable equipment in such a manner as to prevent damage to pipe and accessories. PIPE AND ACCESSORIES SHOULD NEVER BE DROPPED OR DUMPED INTO THE TRENCH.

CAUTION: Heavy impact may cause a slight longitudinal indentation in the outside of the pipe and a crack on the inside. This will result in a split as soon as the pipe is placed under pressure. Any pipe that has been impacted should be examined closely for this type of damage.

3.3 ASSEMBLY OF JM EAGLE™ PVC PIPE

The joint assembly is a push-on assembly in which the lubricated spigot end is inserted under the rubber gasket and into the bell as described in this installation guide. The joint assembly provides for the completion of tight, dependable joints in minimum time when the following procedure is adhered to.

3.4 ASSEMBLY INSTRUCTIONS

JM Eagle™ supplies a standard gasket for water service with its pressure products and an oil resistant gasket under special request. The correct gasket for water service is not marked with any identifiers. The oil resistant gasket for special services has a blue band on the visible gasket face. Be sure you have the correct gasket for the installation. If you require oil resistant gaskets and those provided are for water service, contact JM Eagle™ immediately. Do not use the water service gaskets or try to replace them. Note that either ring type may be used for conveying potable water. Field removal and replacement of gaskets is not recommended.

1. Make certain that the gasket and bell is clean, with no dirt or foreign material that could interfere with proper seating of the gasket or assembly. If necessary, wipe the gasket and bell with a clean, dry cloth, as seen in [Figure 7](#). Lubricating the gasket is not recommended.
2. Make sure pipe end is clean. Wipe with a clean dry cloth around the entire circumference from the end to 1 inch beyond the reference mark.
3. Lubricate the spigot end of the pipe, using only the JM Eagle™-approved pipe lubricant (NSF approved) supplied. Be sure to cover the entire spigot end circumference, with particular attention paid to the beveled end of the spigot. (See [Figure 8](#).) The coating should be the equivalent of a brush coat of enamel paint. Lubricant can be applied to the pipe by hand, cloth, pad, sponge or glove. Lubrication of the gasket and/or ring groove may result in displacement during assembly.



Figure 7

CAUTION: After spigot end is lubricated, do not allow it to contact the bedding material. Small pieces of stone or soil may adhere to the lubricant and may become lodged between the spigot and the gasket upon assembly, resulting in a possible leak.



Figure 8

NOTICE: The JM Eagle™ lubricant supplied with each shipment has been tested and approved for potable water service. Do not use non-approved lubricant, which may harbor bacteria or damage the gaskets or drinking water.

4. Insert the beveled spigot end into the bell so that it is in contact with the gasket. Hold the pipe lengths being joined close to the ground (as shown below) and keep the lengths in proper alignment. Brace the bell, as shown in [Figure 9](#), while the spigot end is inserted under the gasket, so that previously completed joints in the line will not be closed up or over-assembled. Push the spigot end in until the reference mark on the spigot end is flush with the end of the bell, as seen in [Figure 10](#). Stabbing is not recommended and should be avoided to prevent damage to the gasket and joint.



Figure 9

CAUTION: If joint is over-assembled, causing the spigot to jam into the neck of the bell, flexibility of the joint is lost. Uneven settlement of the trench or additional loading may cause this type of joint assembly to leak or crack. Do not assemble beyond the reference mark.

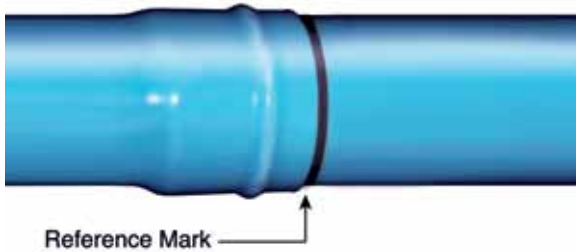

Figure 10

If undue resistance to insertion of the beveled end is encountered or the reference mark does not reach the flush position, disassemble the joint and check the position of the gasket. If it is twisted or pushed out of its seat, do not attempt to realign gasket, replace with another piece of pipe. Be sure both lengths are in proper alignment.

NOTICE: Should a spigot or bell end become deformed under load at higher temperatures, it will be necessary to exercise more care in assembling the joint in order to prevent fish-mouthing of the gasket.

5. No deflection at joint is allowed on 12-inch and smaller pipe. Pipe curvature should be accomplished by bending the pipe rather than deflecting the joints as noted in [Section 2.2](#).

NOTICE: If a pry bar, or backhoe is used for any assembly, a wood plank should be placed between the pipe and the machine to prevent damage. In addition, the force applied must be steady and constant. Do not ram or hit the pipe. For all pipe, a come-a-long jack is recommended over a backhoe. The method of attachment to the pipe must not abrade or damage the pipe in any way. Steps must be taken during installation using these methods to maintain correct alignment of the pipe. As well, a helper should be present in all cases to assist the operator in knowing when the reference mark is reached properly.

3.5 CUTTING

A square cut is essential to ensure proper assembly and/or beveling. PVC pipe can easily be cut with a fine-toothed hacksaw, handsaw or a power type saw with a steel blade or abrasive disc. (See [Figure 11](#).) (Do not use standard pipe cutters. The cutting wheel may crush or damage the pipe.) It is recommended that the pipe be marked around its entire circumference prior to cutting to ensure a square cut. Do not burn the pipe while cutting.



Figure 11

NOTICE: JM Eagle™ recommends using proper personal protective equipment, such as gloves and safety glasses, when cutting PVC pipe.

3.6 BEVELING

Use a factory-finished beveled end as a guide to determine the angle and length of taper. The end may be beveled using a plastic pipe-beveling tool as shown, which will cut the correct taper automatically or such tools as the Stanley “Surform” No. 399, a coarse file or rasp. A portable sander or abrasive disc may also be used to bevel the pipe end. Remove all burrs and raised edges prior to assembly to avoid cutting the gasket.

3.7 LOCATING REFERENCE MARK

With a pencil, crayon or permanent marker, locate the reference mark at the proper distance from the beveled end. The reference mark may also be located accurately by using a factory-marked end of the same pipe as a guide.

3.8 ASSEMBLY AT FITTINGS AND ADAPTORS

JM Eagle™ PVC Blue Brute™, Big Blue™ and Ultra Blue™ pipe is manufactured with a Cast Iron Outside Diameter. This means that this pipe can be directly connected to C.I.O.D. products and fittings such as ductile iron accessories.

No extra support need be provided for these fittings and adaptors, but any heavy metal fittings or valves must be individually supported to avoid differential settlement between fittings and pipe. Note that fittings and valves in-line will require thrust blocking as specified in [Section 3.9](#).

NOTICE: Solvent Weld PVC fittings can not be used with Ultra Blue™ pipe.

NOTICE: Use only M.J. fittings approved for use with AWWA C909 pipe. Follow M.J. fittings manufacturer’s assembly recommendations.

NOTICE: The use of certain mechanical joint butterfly valves with DR 14 PVC pipe may require special adaptors due to interference of the pipe wall and valve flap. Do not cut or trim the pipe wall to avoid decreasing the pressure rating.

Fittings and adaptors are usually installed at predetermined locations and therefore, a tie-in length of less than 20 feet will usually be required.

1. Be sure the correct gasket is used with the iron bell or fitting. Do not use the PVC gasket.
2. Bevel on the spigot should approximate the cast iron bevel, which is shorter and steeper. The reason for this is that the depth of the bell or fitting is shorter than the PVC bell. The reduced length of taper will allow a greater flat sealing surface and minimize the possibility of the gasket seating on the bevel, which may cause leakage.
3. When connecting to a mechanical joint or flanged fitting, a beveled spigot is not recommended or required. Cut off beveled end of pipe prior to insertion into JM Eagle™ style fitting. Deburr and round off cut edge so as not to cut the gasket.

3.9 THRUST BLOCKING AND ANCHORAGE AT FITTINGS

Thrust blocking ([Figure 12](#)) is needed wherever the pipeline:

1. Changes direction, as at tees, bends or crosses.
2. Changes in size, as at reducers.
3. Stops, as at dead ends.
4. Valves at which thrust develops when closed or partially closed.

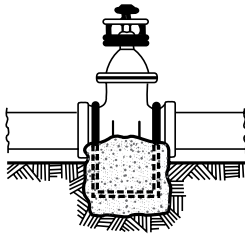

Figure 12

3.9.1 DETERMINING SIZE AND TYPE OF THRUST BLOCKING

Size and type of blocking depends on pressure, pipe size, kind of soil and type of fitting. Common thrust block configurations are shown in [Figure 13](#). At vertical bends, anchor pipelines to resist outward or horizontal thrusts as shown in [Figure 14](#). If thrusts due to high pressure are expected, anchor the valves as shown in [Figure 15](#). In all cases, thrust blocking and anchorages

should be designed by a competent engineer to ensure adequate safety and support based on the actual field conditions encountered. Failure to design thrust blocking and anchorage adequately may result in damage to the pipe, property, and/or people.

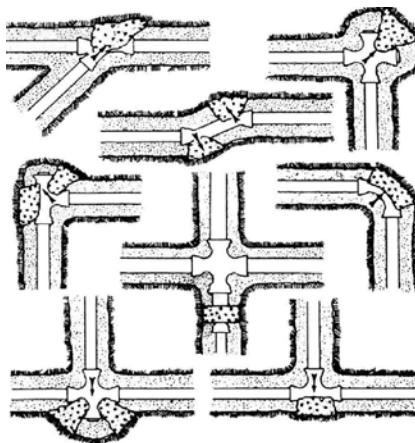

Figure 13

If the engineer has not specified the size of a thrust block, take the following steps to determine the bearing area required for a thrust block.

EXAMPLE: A 90-degree bend for an 8-inch 200 psi line, which will be tested at 200 psi. Soil is sand.

1. Refer to [Table 4](#) and note that the thrust developed for each 100 psi water pressure at an 8-inch 90-degree bend is 9,100 pounds. Yielding a total thrust developed of 18,200 lbs.
2. In [Table 5](#), find that the bearing power of sand is 2,000 pounds per square foot (psf). Dividing the total force of 18,200 pounds by 2,000 psf, we have a total area of thrust backing required of 9.1 square feet or an area of 3 feet by 3 feet.

NOTICE: Allowance in total bearing area should be made for possible water hammer in the line.

THRUST (psf) AT FITTINGS PRODUCED BY 100 psi OF WATER PRESSURE IN JM EAGLE™ PVC PRESSURE PIPE			
PIPE SIZE (inches)	FITTING		
	90 BEND	45 ELBOW	TEE AND PLUGS
4	2,560	1,390	1,810
6	5,290	2,860	3,740
8	9,100	4,920	6,430
10	13,680	7,410	9,860
12	19,350	10,470	13,690
14	25,990	14,100	18,380
16	33,630	18,280	23,780
18	42,230	22,970	29,860
20	51,820	28,180	36,640
24	73,930	40,200	52,280
30	113,946	61,927	80,425
36	163,228	88,711	115,209
42	220,353	119,757	155,528
48	278,188	151,189	196,350

Table 4

ALLOWABLE BEARING OF SOILS	
SOIL	BEARING (psf)
Muck, peat, etc.	0
Soft Clay	1,000
Sand	2,000
Sand and Gravel	3,000
Sand and Gravel cemented with Clay	4,000
Hard Shale	10,000

Table 5

* JM Eagle™ assumes no responsibility for the bearing load data, which was compiled from various sources. The engineer is responsible for determining safe bearing loads and when doubt exists, soil-bearing tests should be

specified. The bearing loads given are for horizontal thrusts when depth of cover is 2 feet.

In soft, unstable soils such as muck or peat, thrusts are resisted by running corrosion-resistant tie rods to solid foundations or by removing the soft material and replacing it with a ballast of sufficient size and weight to resist the thrusts developed.

Pre-cast thrust blocks should not be placed directly against PVC pipe to avoid point loading and provide adequate force distribution.

3.9.2 UPWARD THRUSTS AT FITTINGS

Where a fitting is used to make a vertical bend, anchor the fitting to a thrust block braced against undisturbed soil. The thrust block should have enough resistance to withstand upward thrusts at the fitting. See [Figure 14](#).

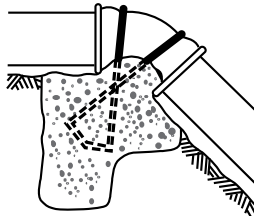

Figure 14

3.9.3 ANCHORAGE OF PIPE ON SLOPES

Anchors on slopes are needed only when there is the possibility of backfill slipping downhill and carrying the pipe with it. Usually, well-drained soil, carefully tamped in 4-inch layers up to the top of the trench, will not slide and pipe anchors will not be required.

Where soil slippage is a possibility, anchors keyed in undisturbed soil can be fastened to every other length of pipe.

3.9.4 ANCHORAGE OF VALVES IN THE LINE

Under pressure conditions, valves must be anchored, as shown in [Figure 15](#), against the thrust created when the valve is closed or partially closed. The area of undisturbed soil, which braces the thrust block, must be large enough to withstand the thrust in whatever direction it is exerted.

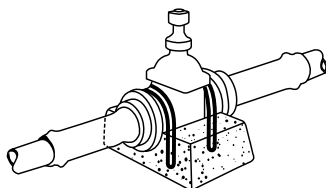

Figure 15

3.9.5 CONSTRUCTION OF THRUST BLOCKING

1. Concrete thrust blocks are constructed by pouring concrete between the fitting and the undisturbed bearing wall of the trench. A dry mixture is prepared so that the concrete may be easily shaped into the desired form, a wedge with the wide end against the solid wall. Note the shapes and positions of the thrust blocks in the drawings.
2. Cinder blocks, wood, dry sand-cement mix or other materials may be used for pipe sizes less than 6 inches provided that (a) there is sufficient bearing area between backing and fitting, and (b) the backing has sufficient strength to withstand the thrust load. If wood is used, it must be treated to prevent deterioration.
3. As an alternative, mechanical thrust restrainers may be used to resist the thrust developed.

3.10 INSTALLATION AT HYDRANTS

Each hydrant run-out is normally equipped with a valve. The valve may be located at the main, at the hydrant or in between. Whatever the location, each fitting (branch-tee, gate valve and hydrant) should be separately supported by concrete. Be sure to firmly brace the hydrant while pipe connections are made and until the final foundation has been poured and has set. Do not make the pipe support the hydrant.

A concrete foundation poured around the base of the hydrant after it has been set in position, as seen in [Figure 16](#), will serve as:

- A thrust block.
- A hold-down or anchorage against frost heave.
- A foundation that eliminates washouts from the wastewater discharged through the hydrant drain.

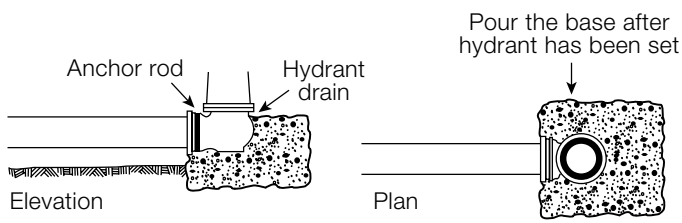

Figure 16

When the fittings are used in a hydrant run-out, seen in [Figure 17](#), a single length can be used to connect two fittings.

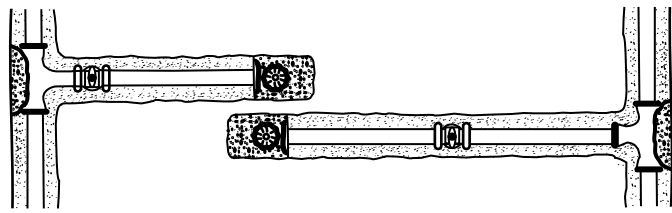

Figure 17

3.11 THRUST-RESTRAINT JOINTS

Various types of thrust-restraint joints are currently promoted for use with PVC pipe. These include couplings, which require grooving the pipe and various fittings with setscrews that bear on the pipe wall. None of these devices can be uniformly recommended by JM Eagle™ for use with our products. Contact JM Eagle™ Product Assurance for specific application information with regard to specific joint restrainers.

Fittings: Ultra Blue™ has ductile iron (DI) outside diameters (OD), making standard PVC gasketed fittings compatible. **(Note: Solvent Weld PVC fittings cannot be used.)** Ductile iron or cast iron mechanical joint fittings and ductile iron push-on-type fittings can be installed directly onto Ultra Blue™, using the standard M.J. gasket made for cast iron or ductile iron pipe. When using M.J. fittings, 55 foot-pounds of torque is recommended.

Joint Restraint Devices: Joint restraint devices that are commonly used with standard PVC can be used with Ultra Blue™.

3.12 SERVICE CONNECTIONS

Service connections may be made to JM Eagle™ PVC pressure pipe by means of direct tapping, saddles or a sleeve and valve in the line at the service location. Due to the in-depth knowledge required to make proper taps safely, please refer to Uni-Bell® Publication UNI-PUB-08-07, "Tapping Guide for PVC Pressure Pipe."

NOTE: Direct tapping is only allowed for DR14 and DR18 C900 pipe in diameters 6-inch through 12-inch.

3.12.1 DIRECT TAPS, SADDLES, AND VALVES

With these connections, a JM Eagle™ PVC pressure pipeline can be tapped before or after the line goes into service. Check with saddle and valve manufacturers for recommended pressure rating of the tools used.

WARNING: Use of improper tapping procedures or tools may result in serious damage to pipe, property and/or people. Do not tap prior to obtaining the complete tapping guide.

4.0 PIPE EMBEDMENT

Figure 18 illustrates a typical trench with all major regions identified, as they will be addressed in the following sections.

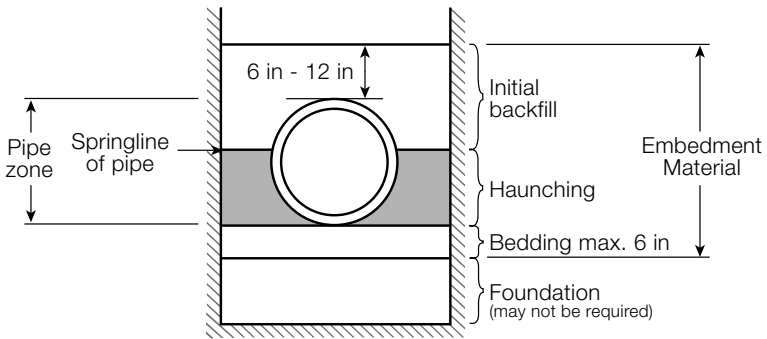

Figure 18

4.1 BEDDING

Bedding is required primarily to bring the trench bottom up to grade. Bedding materials should be placed to provide uniform longitudinal support under the pipe to prevent low spots. Blocking should not be used to bring the pipe to grade. Bell holes at every joint will allow for the joint to be assembled properly and maintain adequate support. Under normal circumstances a bedding of 4 to 6 inches compacted is of sufficient thickness for the bedding. If the native trench soil is comprised of fine-grain soils and migration of those soils into the bedding material is anticipated, either wide-trench construction, a well-graded bedding material without voids, or a fabric barrier should be used to avoid compromising the trench backfill materials.

4.2 BACKFILLING AND TAMPING

Backfilling should follow pipe assembly as closely as possible. This protects the pipe from falling rocks, eliminates possibility of lifting the pipe from grade due to flooding of an open trench, avoids shifting pipe out of line by cave-ins, and in cold weather lessens the possibility of backfill material becoming frozen.

4.2.1 HAUNCHING AND INITIAL BACKFILL

There are two basic purposes of the haunching and initial backfilling of a flexible conduit such as PVC pipe:

1. To provide the soil side support, which is necessary to enable the pipe and the soil to work together to meet the designed load requirements within the allowable deflection limits.
2. To provide protection for the pipe from impact damage due to large rocks, etc., contained in the final backfill.

The essentials of satisfactory haunching and initial backfilling can be summarized as follows: Provide approved materials, properly compacted continuously above the bedding and around the pipe to the spring-line, as well as between the pipe and undisturbed trench walls.

After the bedding material has been placed according to [Section 4.1](#), place the haunching and initial backfill by hand to a 1-foot minimum depth of cover above the pipe to give pipe support and cushion. In doing so, proper control should be exercised to avoid vertical and horizontal displacement of the pipe from proper alignment. This backfill should be a selected material, free from rocks greater than 1.5 inches in diameter, dirt clods or frozen material. This material is solely responsible for providing effective support of the pipe in the haunching area and limiting deflection. This is accomplished by tamping the embedment materials under the haunches and around the pipe to the spring-line of the pipe.

Side support is accomplished by tamping the soil firmly under the haunches of the pipe out to the trench walls. Tamping should be done in layers no greater than 6 inches. If automatic tampers are used, care should be exercised to avoid damaging the pipe. For more information on tamping, see [Section 4.4.1](#).

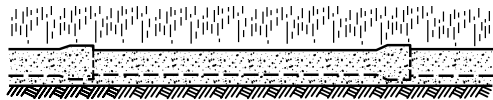

A. **Right**—Backfill correctly placed by hand filling all voids.

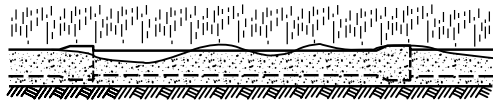

B. **Wrong**—Backfill not placed evenly.

Figure 19

The immediate placement of initial backfill will provide adequate weight of soil on the pipe so that expansion and contraction will be evenly distributed over each pipe length. This portion of the backfill begins at the spring-line of the pipe and extends to some predetermined distance above the pipe. Since little to no side support is derived from the soils placed in this area, native soils maybe used without tremendous compaction efforts, unless in the influence zone of other structures. It should be noted that at shallow depths of cover (less than 3 feet) flexible conduits may deflect and rebound under dynamic loading if the trench width is not highly compacted, resulting in damage to road surfaces. For pipes buried under flexible road surfaces at depths less than 3 feet, it is recommended that a minimum of 90 percent Proctor density be achieved from the bottom of the trench up to the road surface using Class I or Class II materials as described in [Appendix 1](#). Minimum cover is recommended to be 1 foot from the top of rigid road surfaces or the bottom of flexible road surfaces.

NOTICE: For water pipe installations the top area of the bells can be left exposed for visual inspection during the test if required.

4.3 COMPLETING THE BACKFILL

Balance of backfill need not be as carefully selected as the initial material, unless specified by the engineer. Care should be taken, however, to avoid including large stones that could damage the pipe by dropping on it or by being forced down on to the pipe under the weight of the final backfill.

4.3.1 FINAL BACKFILL

The final backfill should be placed and spread in uniform layers in such a manner as to completely fill the trench with a uniformly dense backfill load on the pipe and avoid unfilled spaces in the backfill. Rolling equipment should not be used until a minimum of 18 inches of backfill material has been placed over the top of the pipe. If a hydro hammer is to be used to compact the backfill, a minimum of 3 feet of cover is required. Unless otherwise specified, trenches under pavements, sidewalks, or roads shall be backfilled and compacted to 90 percent density, as determined by the [American Association of Highway and Transportation Officials Method](#)

T99 for State Compaction and Density of Soils. Unless specified, other trenches may be backfilled without controlled compaction in the final backfill. Additional backfill material should be supplied, if needed, to completely backfill the trenches or to fill depressions caused by subsequent settlement.

For description of backfill materials and their recommended usage, please refer to [Appendix 1](#).

4.4 COMPACTION METHODS

The first step in providing effective support for the pipe in the haunching area is to tamp the embedment materials under the haunches and around the pipe to the spring-line of the pipe.

Tamping should be done with hand tamping bars, mechanical tampers, or by using water to consolidate the embedment materials. With hand tamping, satisfactory results can be accomplished in damp, loamy soils and sands. For more cohesive soils, the necessary compaction may require the use of mechanical tampers. Water tamping should be limited to trenches excavated in soils in which water drains through quickly and, in so doing, compacts the embedment material.

4.4.1 TAMPING BARS

Two types of tamping bars should be available for a good tamping job. The first should be a bar with a narrow head. (See [A](#) or [B](#) of [Figure 20](#).) These are used to tamp under the pipe. The second tamping bar should have a flat head. It is used to compact the soil along the sides of the pipe to the trench walls. (See [Figure 20 C](#).)

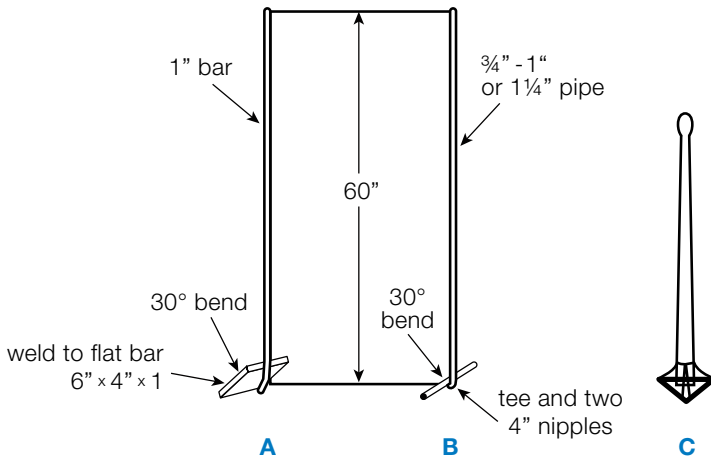

Figure 20

Do not attempt to use the flat tamper (C) in place of A or B.

4.4.2 MECHANICAL TAMPERS

Care should be taken to avoid contact between the pipe and compaction equipment. Compaction of the embedment material should generally be done in such a way that the compaction equipment is not used directly above the pipe until sufficient backfill has been placed to ensure that the use of compaction equipment will not damage the pipe or cause deflection of the pipe. When hydro-hammers are used to achieve compaction, they should not be used within 3 feet of the top of the pipe and then, only if the embedment material density has been previously compacted to a minimum 85 percent Proctor density.

4.4.3 FLOOD OR WATER TAMPING

Flooding or water tamping should be used only in trenches that are excavated in soils from which water drains quickly and, at the same time, compacts the haunching material.

If flooding is used, the approved embedment material is first hand placed, making certain all voids under, around and along both sides of the pipe and

couplings are filled. Initial embedment material should be placed to a height sufficient to prevent floating of the pipe.

4.4.4 WATER-JETTING

The introduction of water under pressure to the embedment material is not to be used to compact the embedment material of PVC pipe, or any other flexible conduit.

4.4.5 SHEETING AND TRENCH BOXES

When sheeting is used, it should be left in place unless it is designed to prevent disturbing the soil adjacent to the pipe when pulled and removed. If heavy wooden sheeting has to be pulled, well-graded granular material should be placed on each side of the pipe for a distance of at least two pipe diameters. The granular material should be compacted to at least 90 percent standard Proctor density.

Whenever possible, sheeting and bracing should be installed so that the bottom of the sheeting extends no lower than the spring-line of the pipe. When installed in this manner, pulling the sheeting will not disturb the embedment material providing sidewall support for the pipe. If a trench box is used, it should be designed so that the back end of the sides do not extend below the pipe spring-line. This will allow filling and compaction of the annular space as the trench box is moved forward.

5.0 PIPE TESTING AND REPAIR

5.1 PIPE DEFLECTION

Under ordinary circumstances the deflection of PVC pressure pipe is of no concern because the internal pressure of the pipe is much greater than the external load placed on the pipe, thus no deflection occurs. However, in some cases, these pipes are used for force mains or gravity flow applications. Towns and municipalities normally set the long-term deflection limits of PVC at 7.5

percent by ASTM D3034 (Appendix), to provide a very conservative factor of safety against structural failure. However, it should be noted that PVC sewer pipe will have a minimum safety factor of 4 in structural failure at this limit. To ascertain how a certain PVC product will deflect under various loading conditions, backfill types, and depths one may contact JM Eagle™ for design charts specific to a situation.

5.1.1 DEFLECTION TESTING

It is the position of JM Eagle™ that deflection testing of PVC pipe is unnecessary when pipe is installed in accordance with the acceptable practices stated in this guide. Most towns and municipalities limit initial deflection to 5 percent, when in actuality ASTM D3034 recommends PVC pipe deflection at 7.5 percent of base inside diameter. Thus, exceeding these limits does not necessarily indicate any structural damage, failure or reduction in life and only add to the cost of the project. Proof of this position is that more than 750,000,000 feet of PVC sewer pipe are performing satisfactorily in the field today. On the other hand, where improper installation practices are known or suspected, questionable bedding materials are employed, and/or installation conditions are severe, deflection testing of these sections of the installation should be considered advisable by the engineer. In the event that deflection measurement is a requirement, please consult JM Eagle™ Publication JME-05B, “Gravity Sewer Installation Guide.”

5.2 TESTING WATER PIPE

It is good practice to pressure test portions of a line as it is installed—before the entire line is completed. Before testing, all parts of the line should be backfilled and braced sufficiently to prevent movement under pressure.

In setting up a section of line for test, a provision for air relief valves should be made.

There are three parts of the line to consider when testing:

1. The run of pipe, which must be backfilled sufficiently to prevent movement under test pressure.

2. Thrust blocks at fittings, which should be permanent and constructed to withstand test pressure. If concrete thrust blocks are used, enough time to permit the cement to set must elapse before testing.
3. Test ends, which should be capped and braced to withstand the appreciable thrusts that are developed under test pressure, as seen in [Figure 21](#). Refer to [Section 3.9](#) on “Thrust Blocking and Anchorage at Fittings.”

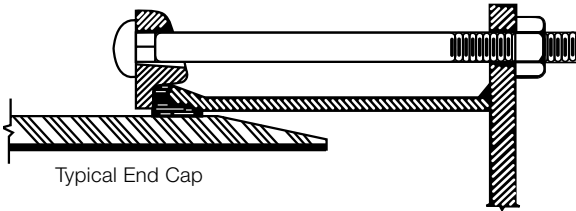

Figure 21

The last full length laid should be firmly wedged and braced to prevent kicking out under pressure, as seen in [Figure 22](#). (All exposed pipe must be wedged or backfilled, in order to hold it securely in line.) Using a plumb bob over a reference point on the pipe will check creeping when pressure is built up.

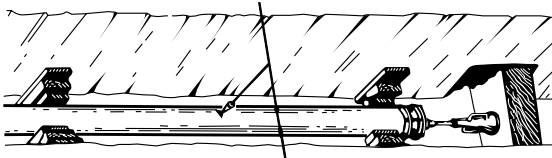

Figure 22

5.2.1 FILLING THE LINE

The line can be slowly filled from any available low-pressure source. The water can be introduced from lines in service through valve connections, by temporary connections to hydrants, to taps made in the new line, or at the connection in the end cap. All such connections, however, should be made at the lowest point in the line, if possible, to help eliminate air entrapment. Where a portion of the line is to be tested and has not yet been tied to the final source, some other source of water must be found. [Table 6](#) shows the approximate volume of water required for filling JM Eagle™ PVC Blue Brute™, Big Blue™ and Ultra Blue™ pipe.

VOLUME OF WATER REQUIRED IN GALLONS/FOOT						
PIPE SIZE (inches)	C900/C905 PIPE DR					
	51	41	32.5	25	18	14
4	—	—	—	0.79	0.73	0.68
6	—	—	—	1.62	1.51	1.40
8	—	—	—	2.80	2.60	2.41
10	—	—	—	4.21	3.91	3.62
12	—	—	—	5.95	5.54	5.12
14	—	—	8.34	8.00	7.44	—
16	—	—	10.80	10.34	9.61	—
18	—	—	13.56	13.00	12.07	—
20	—	—	16.63	15.95	14.82	—
24	—	—	23.74	22.74	21.14	—
30	38.38	37.58	36.50	35.00	—	—
36	54.98	53.76	52.29	50.12	—	—
42	74.22	72.59	70.61	67.68	—	—
48	96.72	94.55	92.02	88.18	—	—

VOLUME OF WATER REQUIRED IN GALLONS/FOOT				
PIPE SIZE (inches)	AWWA C909			ASTM F1483
	PC100	PC150	PC200	PR200
6	—	1.70	1.64	1.59
8	—	2.93	2.81	2.70
10	—	4.41	4.24	4.19
12	—	6.24	5.99	5.90
16	11.29	—	—	—

Table 6

5.2.2 RELIEVING AIR FROM THE LINE

ALL AIR SHOULD BE VENTED FROM ALL HIGH SPOTS IN THE PIPELINE BEFORE MAKING EITHER PRESSURE OR LEAKAGE TESTS. AUTOMATIC AIR RELEASE VALVES ARE RECOMMENDED. Compressed entrapped air causes difficulty in pumping to required pressure for strength tests. Furthermore, a pipeline may leak compressed air when it is actually watertight. If this occurs during a leakage test, it will cause erroneous results. Most importantly, when entrapped air is compressed, it poses a severe explosion hazard and may result in pipe failure and/or injury to property and/or persons. Don't use PVC for compressed-air systems.

5.3 PRESSURE-STRENGTH TESTS

The purpose of a pressure-strength test is to make certain that the line will withstand normal working pressure plus reasonable excesses that may occur. In a properly designed line, excess pressures will be kept to a minimum by the use of automatic relief valves, slow closing and opening valves, slow pump starting and other controls. A test pressure of 25 percent above the normal operating pressure should generally be sufficient, unless the specification calls for greater pressure. Do not build test pressures greater than those specified. This can happen if the pressure is read from a gauge located at a high point in the line. In such cases the actual pressure at low points will be greater and might cause damage to the line. In all cases, it is important that no pressure test, regardless of duration, exceed the marked pressure capacity of the pipe and/or accessories being tested. Doing so might cause damage to the line or shorten the expected life of the system. For more detailed instructions on how to perform installation and pressure testing, please consult [ASTM D2774](#), “Standard Practice for Underground Installation of Thermoplastic Pressure Piping” and/or the appropriate AWWA standards.

5.4 MAKING LEAKAGE TESTS

The purpose of a leakage test is to establish that the section of line to be tested—including all joints, fittings, and other appurtenances—will not leak or that the leakage established is within the limits of the applicable leakage allowance. Leakage, if any, is usually involved in joints at saddles, valves, transition fittings and adaptors not usually in pipe joints. Normal operating pressure is usually applied for tests. This should be maintained as constant as possible throughout the testing period. Measurement of the amount of additional water pumped in during the test will provide a measurement of the amount of leakage, if any. In setting up a section of line for testing, air relief valves should be provided. Air trapped in the line during the test will affect test results and can cause damage to the pipeline and/or injury to workers.

Generally, the engineer will establish the duration of the test, the allowable leakage, and indicate the appropriate methods and procedures for testing. If not, a two-hour test is recommended and the allowable leakage shall be determined by the following formula:

$$L = (ND\sqrt{P}) / 7400$$

L is the allowable leakage, in gallons per hour; N is the number of joints in the length of pipeline tested; D is the nominal diameter of the pipe in inches; and P is the average test pressure during the test in pounds per square inch gauge (PSIG). Leakage values determined by the above formula are shown in [Table 7](#).

LEAKAGE ALLOWANCE GALLONS PER 100 JOINTS PER HOUR					
PIPE SIZE (inches)	TEST PRESSURE (psi)				
	50	100	150	200	225
4	0.38	0.54	0.66	0.76	0.81
6	0.57	0.81	0.99	1.15	1.22
8	0.76	1.08	1.32	1.53	1.62
10	0.96	1.35	1.66	1.91	2.03
12	1.15	1.62	1.99	2.29	2.43
14	1.34	1.89	2.32	2.68	2.84
16	1.53	2.16	2.65	3.06	3.24
18	1.72	2.43	2.98	3.44	3.65
20	1.91	2.70	3.31	3.82	4.05
24	2.29	3.24	3.97	4.59	4.86
30	2.87	4.05	4.97	5.73	6.08
36	3.44	4.86	5.96	6.88	7.30
42	4.01	5.68	6.95	8.03	8.51
48	4.59	6.49	7.94	9.17	9.73

Table 7

Consideration should be given to any valves isolating the test section. Many waterworks valves are not designed for leak-proof operation. Leakage through these valves can distort actual leakage figures.

The leakage allowances indicated are intended for municipal water pipe distribution networks, which include numerous valves and fittings. However, JM Eagle™ PVC Blue Brute™, Big Blue™ and Ultra Blue™ Pressure pipe can meet the tighter leakage allowances of [NFPA 24, “Standard for Outside Protection \(Firelines\).”](#) Potable water lines may require disinfecting per AWWA standards.

5.5 MAKING REPAIRS TO DAMAGED PIPELINES

When pipe has been damaged and repair is required, all damaged material may be replaced in kind or the pipe may be repaired using a repair clamp or other methods authorized by the engineer.

If a repair clamp is to be used, the full circle type with opposed bolt line flanges is recommended and should be installed in accordance with the manufacturer's instructions.

Gouges that have a depth greater than 10 percent of the wall thickness of the pipe, should be repaired. If the damaged area is localized, a repair clamp may be used. When the damaged area extends beyond a localized area, it is recommended that the damaged section of the pipe be cut out and replaced. In such cases, repair clamps or Dresser-type couplings will be required to join the pipe ends. Other types of couplings may be available. Please consult JM Eagle™ for acceptability of these other products.

NOTE: Trenches and/or casing should be constructed and used in accordance with all applicable state and federal standards to ensure safety.

NOTICE TO ALL READERS OF THIS GUIDE: PVC pipe installation may be hazardous to pipe, property and/or people if this guide and/or the recommendations of JM Eagle™ are not adhered to fully. JM Eagle™ has made every effort to expose all known dangers of misusing PVC pipe in this guide; however, JM Eagle™ cannot possibly know or anticipate all situations or outcomes. JM Eagle™ maintains the position that PVC pipe is the most reliable and safest piping material available. Thus, JM Eagle™ encourages all users of its products to exercise good judgment when installing our products and to consult JM Eagle™ for additional information when questions or concepts illustrated herein are not fully answered or understood. It is recommended that all users of its products (or people handling) attend training on pipe construction, installation and safety prior to working with its products to ensure safety, knowledge and understanding. Should you need further assistance, please contact [JM Eagle™ Product Assurance at 1-800-621-4404](tel:1-800-621-4404).

APPENDIX 1

EMBEDMENT MATERIALS

Materials suitable for foundation and embedment are classified in [Table A1.1](#). They include a number of processed materials plus soil types defined according to the Unified Soil Classification System (USCS) in [ASTM D2487](#), “[Standard Method for Classification of Soils for Engineering Purposes.](#)” [Table A1.2](#) provides recommendations on the installation and use based on class of soil or aggregates and location within the trench. It is important to engineer all materials used in the pipe trench to work together and with the native material surrounding the trench.

Class IA Materials: Class IA materials provide the maximum stability and pipe support for a given density because of the angular interlocking of the material particles. With minimum efforts, these materials can be installed at relatively high densities over a wide range of moisture contents. These materials also have excellent drainage characteristics that may aid in the control of water. These soils are often desirable as embedment in rock cuts where water is frequently encountered. On the other hand, when ground water flow is anticipated, consideration should be given to potential migration of fines from adjacent materials into the open graded Class IA materials.

Class IB Materials: Class IB materials are produced by mixing Class IA and natural or processed sands to produce a particle-size distribution that minimizes migration from surrounding soils that may contain fines. They are more widely graded than Class IA and thus require more compaction effort to achieve the minimum density specified. When these materials are properly compacted these soils exhibit high stiffness and strength, and depending on the amount of fines, may be relatively free draining.

Class II Materials: When Class II materials are compacted, they provide a relatively high level of pipe support. In most respects, they all have the desirable characteristics of Class IB materials when widely graded. However, open-graded groups may allow for migration and the sizes should be checked for compatibility with the native trench materials. Typically, Class II materials consist of rounded particles and are less stable than the angular materials of Class IA and IB unless they are confined and compacted.

Class III Materials: These materials provide less support for a given density than Class I or Class II materials. High levels of compaction effort are required if moisture content is not controlled. These materials will provide reasonable support once proper compaction is achieved.

Class IV-A Materials: Class IV-A materials must be carefully evaluated before use. The moisture content of the materials must be near optimum to minimize compaction effort and achieve the required density. Properly placed and compacted, these soils can provide reasonable levels of pipe support. However, these materials may not be suitable under high fills, surface applied dynamic loads, or under heavy vibratory compactors and tampers. These materials should be avoided if water conditions in the trench may cause instability and result in uncontrolled water content.

Table A1.1

Description of Material Classification as Defined in ASTM D2321

Class	Type	Soil Symbol Group	Description ASTM D2487	Percentage Passing Sieve Sizes			Atterberg Limits		Coefficients	
				1.5 in (40 mm)	No.4 (4.75 mm)	No.200 (.075 mm)	LL	PL	Uniformity Cu	Curvature Cc
IA	Manufactured Aggregates: open graded, clean	None	Angular, crushed stone or rock, crushed slag, cinders or shell: large void content, contain little or no fines	100%	< or = 10%	< 5%	Non Plastic			
IB	Manufactured, Processed Aggregates: dense graded, clean	None	Angular, crushed stone (or other Class IA materials) and stone/sand mixtures with gradations selected to minimize migration of adjacent soils: contain little to no fines	100%	< or = 50%	< 5%	Non Plastic			
II	Coarse-Grained Soils: clean	GW	Well graded gravels and gravel-sand mixtures: little to no fines	100%	< 50% of coarse fraction	< 5%	Non Plastic		> 4	1 to 3
		GP	Poorly graded gravels and gravel-sand mixtures: little to no fines						< 4	< 1 or > 3
		SW	Well graded sands and gravelly sands: little to no fines		< 50% of coarse fraction				> 6	1 to 3
		SP	Poorly graded sands and gravelly sands: little to no fines						< 6	< 1 or > 3
	Coarse-Grained Soils: borderline clean to w/fines		Sands and gravels which are borderline between clean and with fines	100%	varies	5% to 12%	Non Plastic			Same as for GW, GP, SW, and SP

Based on tables found in the Uni-Bell® PVC Pipe Association, "Handbook of PVC Pipe Design and Construction."

Table A1.1 continued

Class	Type	Soil Symbol Group	Description ASTM D2487	Percentage Passing Sieve Sizes			Atterberg Limits		Coefficients	
				1.5 in (40 mm)	No.4 (4.75 mm)	No.200 (.075 mm)	LL	PL	Uniformity Cu	Curvature Cc
III	Coarse-Grained Soils w/ Fines	GM	Silty gravels, gravel-sand-silt mixtures	100%	> 50% of coarse fraction	> 12% to < 50%		< 4 or < "A" Line		
		GC	Clayey gravels, gravel-sand-clay mixtures					< 7 and > "A" Line		
		SM	Silty sands, sand-silt mixtures		> 50% of coarse fraction			> 4 or < "A" Line		
		SC	Clayey sands, sand-silt mixtures					> 7 and > "A" Line		
IV-A	Fine-Grained Soils: Inorganic	ML	Inorganic silts and very fine sands, rock flour, silty or clayey fine sands, silts with slight plasticity	100%	100%	> 50%	< 50	< 4 or < "A" Line		
		CL	Inorganic clays of low to medium plasticity, gravely clays, sandy clays, silty clays, lean clays					> 7 and > "A" Line		

Based on tables found in the Uni-Bell® PVC Pipe Association, "Handbook of PVC Pipe Design and Construction."

Table A1.2

Recommendations for Installation and Use of Soils and Aggregates for Foundation, Embedment, and Backfill

Soil Class as Defined in Table A1.1

	Class IA	Class IB	Class II	Class III	Class IV-A
General Recommendations and Restrictions	Do not use where conditions may cause migration of fines from adjacent soil and loss of pipe support. Suitable for use as a drainage blanket and underdrain in rock cuts where adjacent material is suitably graded.	Process materials as required to obtain gradation which will minimize migration of adjacent materials. Suitable for use as drainage blanket and underdrain.	Where hydraulic gradient exists check migration. "Clean" groups suitable for use as drainage blanket and underdrain.	Do not use where water conditions in trench may cause instability	Obtain geotechnical evaluation of processed material. May not be suitable under high earth fills, surface applied loads and under heavy vibratory compactors and tampers. Do not use where water conditions in trench may cause instability.
Foundation	Suitable as foundation and for replacing over-excavated and unstable trench bottom as restricted above. Install and compact in 6-inch maximum layers.	Suitable as foundation and for replacing over-excavated and unstable trench bottom. Install and compact in 6-inch maximum layers.	Suitable as foundation and for replacing over-excavated and unstable trench bottom as restricted above. Install and compact in 6-inch maximum layers.	Suitable as foundation and for replacing over-excavated trench bottom as restricted above. Do not use in thicknesses greater than 12 inches total. Install and compact in 6-inch maximum layers.	Suitable only in undisturbed condition and where trench is dry. Remove all loose material and provide firm, uniform trench bottom before bedding is placed.

Based on tables found in the Uni-Bell® PVC Pipe Association, "Handbook of PVC Pipe Design and Construction."

Table A1.2 continued

Soil Class as Defined in Table A1.1					
	Class IA	Class IB	Class II	Class III	Class IV-A
Bedding	Suitable as restricted above. Install in 6 inch maximum layers. Level final grade by hand. Minimum depth 4 inches (6 inches in rock cuts).	Install and compact in 6 inch maximum layers. Level final grade by hand. Minimum depth 4 inches (6 inches in rock cuts).	Suitable as restricted above. Install and compact in 6-inch-maximum layers. Level final grade by hand. Minimum depth 4 inches (6 inches in rock cuts).	Suitable only in dry trench conditions. Install and compact in 6-inch-maximum layers. Level final grade by hand. Minimum depth 4 inches (6 inches in rock cuts).	Suitable only in dry trench conditions and when optimum placement and compaction control is maintained. Install and compact in 6 inch maximum layers. Level final grade by hand. Minimum depth 4 inches (6 inches in rock cuts).
Haunching	Suitable as restricted above. Install in 6 inch maximum layers. Work in around pipe by hand to provide uniform support.	Install and compact in 6 inch maximum layers. Work in around pipe by hand to provide uniform support.	Suitable as restricted above. Install and compact in 6-inch-maximum layers. Work in around pipe by hand to provide uniform support.	Suitable as restricted above. Install and compact in 6-inch-maximum layers. Work in around pipe by hand to provide uniform support.	Suitable only in dry trench conditions and when optimum placement and compaction control is maintained. Install and compact in 6 inch maximum layers. Work in around pipe by hand to provide uniform support.
Initial Backfill	Suitable as restricted above. Install to a minimum of 6 inches above pipe crown.	Install and compact to a minimum of 6 inches above pipe crown.	Suitable as restricted above. Install and compact to a minimum of 6 inches above pipe crown.	Suitable as restricted above. Install and compact to a minimum of 6 inches above pipe crown.	Suitable as restricted above. Install and compact to a minimum of 6 inches above pipe crown.
Final Backfill	Compact as required by the engineer.	Compact as required by the engineer.	Compact as required by the engineer.	Compact as required by the engineer.	Suitable as restricted above. Compact as required by the engineer.

Based on tables found in the Uni-Bell® PVC Pipe Association, "Handbook of PVC Pipe Design and Construction".



Revised January 2009
JME-03B
© J-M Manufacturing Co., Inc.



*Building essentials
for a better tomorrow™*

GLOBAL HEADQUARTERS:

Nine Peach Tree Hill Road
Livingston, NJ 07039
T: 973.535.1633
F: 973.533.4185

www.JMEagle.com

REGIONAL OFFICE:

5200 West Century Blvd
Los Angeles, CA 90045
T: 800.621.4404
F: 800.451.4170