

EAGLE CORR PE

4"-10" DUAL WALL

SUBMITTAL AND DATA SHEET

THIS SPECIFICATION REFERS TO 4"-10" PIPE FOR USE IN GRAVITY FLOW DRAINAGE APPLICATIONS.

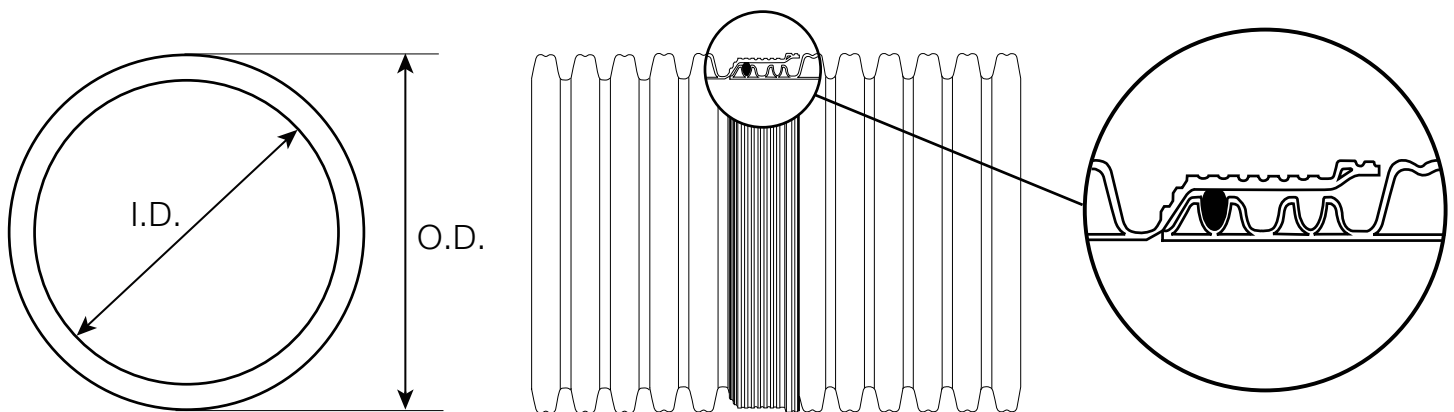

NOMINAL I.D. IN (MM)	APPROX. O.D. IN (MM)	LAYING LENGTH (FT)	PIPE STIFFNESS PSI	AVERAGE UNIT WEIGHT LB/FT
4 (100)	5 (120)	20	50	0.4
6 (150)	7 (174)	20	50	1.1
8 (200)	9 (231)	20	50	1.7
10 (250)	11 (290)	20	50	2.5

PRODUCT STANDARD:	4"-10" AASHTO M252 and ASTM F2648
PIPE COMPOUND:	ASTM D3350
GASKET:	ASTM F477
JOINT PERFORMANCE:	ASTM D3212
FITTINGS:	AASHTO M252; AASHTO F2306; ASTM F2638
INSTALLATION:	ASTM D2321; Eagle Corr PE Installation Guide

EAGLE CORR PE

12"–60" DUAL WALL

SUBMITTAL AND DATA SHEET

THIS SPECIFICATION REFERS TO 12"-60" PIPE FOR USE IN GRAVITY FLOW DRAINAGE APPLICATIONS.

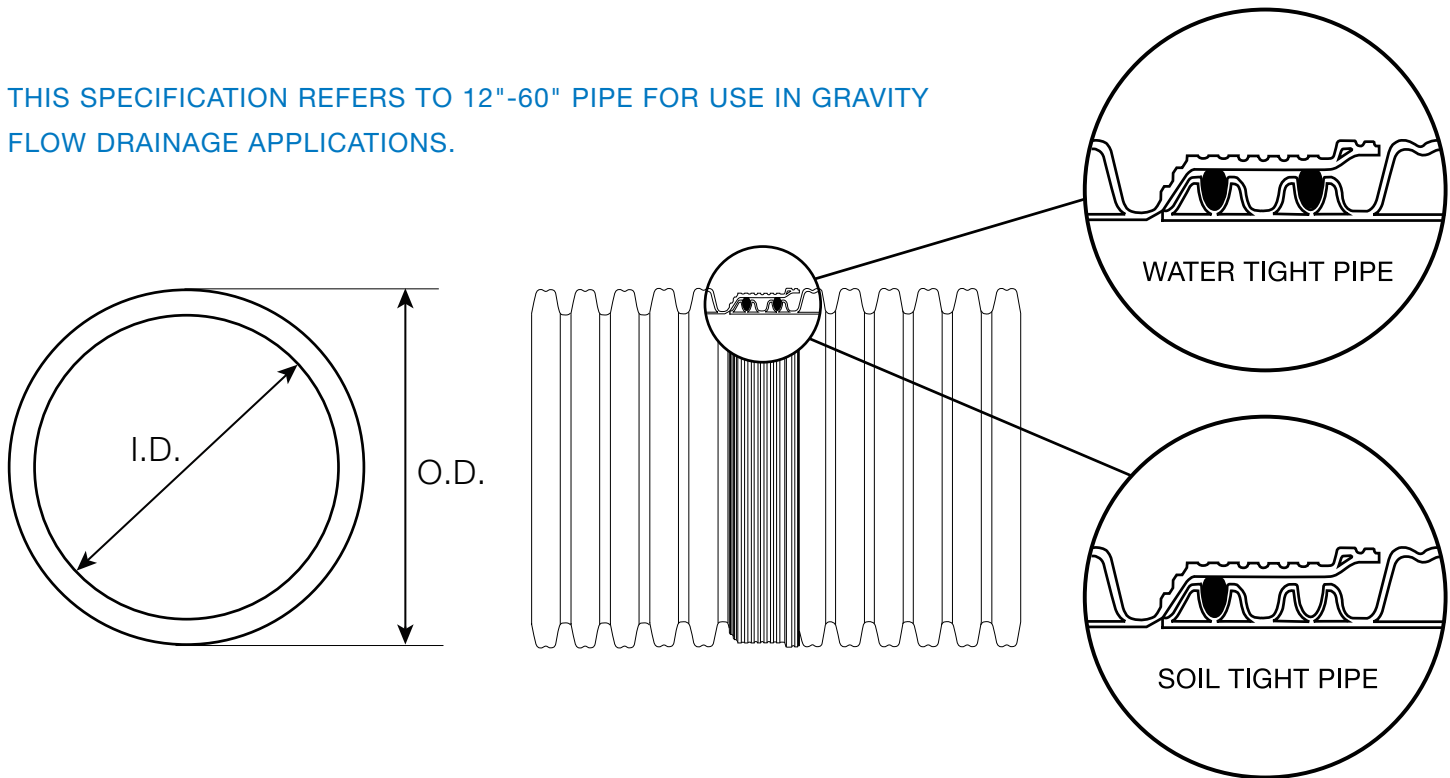

NOMINAL I.D. IN (MM)	APPROX. O.D. IN (MM)	LAYING LENGTH (FT)	PIPE STIFFNESS PSI	AVERAGE UNIT WEIGHT LB/FT
12 (300)	14 (363)	20	50	3.2
15 (375)	17 (444)	20	42	4.8
18 (450)	21 (529)	20	40	6.3
24 (600)	28 (699)	20	34	11.2
30 (750)	35 (880)	20	28	15.8
36 (900)	42 (1055)	20	22	20.9
42 (1050)	47 (1204)	20	20	26.9
48 (1200)	54 (1367)	20	18	34.0
60 (1500)	67 (1693)	20	14	56.0

PRODUCT STANDARD: 12"-60" AASHTO M294, ASTM F2306 and ASTM F2648

PIPE COMPOUND: ASTM D3350

GASKET: ASTM F477

JOINT PERFORMANCE: ASTM D3212

FITTINGS: AASHTO M294; AASHTO F2306; ASTM F2638

INSTALLATION: ASTM D2321; Eagle Corr PE Installation Guide