

SOLVENT WELD

SUBMITTAL AND DATA SHEET

JM EAGLE™ PVC SCHEDULE 30/DWV FOR DRAIN, WASTE, VENT PIPE

Specifications: ASTM D2949 : :

Listed : ANSI/NSF-DWV, Standard 14

NOM. PIPE SIZE (IN)	O.D. (IN)	NOM. I.D. (IN)	MIN. T. (IN)	WATER PRESSURE RATING AT 23°C (73°F)	APPROX. WEIGHT (LBS/FT)
3	3.250	2.980	0.125	None	0.800

: : Cell Class 12454

* Prior to ordering or specifying, please consult JM Eagle™
for product and/or listing availability.

I.D. : Inside Diameter

O.D. : Outside Diameter

T. : Wall Thickness

Product Standard: ASTM D2949

Pipe Compound: ASTM D1784 Cell Class 12454

Certifications: ANSI/NSF Standard 14

End Finish: Plain End

Pipe Length: 10 or 20 feet overall

Installation: JM Eagle™ Installation Guide

CELLULAR CORE PIPE

JM EAGLE™ PVC SCHEDULE 40/DWV CELLULAR CORE PIPE

Specifications: ASTM F891 : :

Listed : ANSI/NSF-DWV Standard 14

NOM. PIPE SIZE (IN)	O.D. (IN)	NOM. I.D. (IN)	MIN. T. (IN)	APPROX. WEIGHT (LBS/FT)
1-1/2	1.900	1.593	0.145	0.383
2	2.375	2.049	0.154	0.500
3	3.500	3.042	0.216	1.050
4	4.500	3.998	0.237	1.450
6	6.625	6.031	0.280	2.450
8	8.625	7.942	0.322	—
10	10.750	9.976	0.365	—
12	12.750	11.889	0.406	—

: : Standard Color: White, Standard Length: 10' & 20',
Plain End and Belled End

* Prior to ordering or specifying, please consult JM Eagle™
for product and/or listing availability.

I.D. : Inside Diameter

O.D. : Outside Diameter

T. : Wall Thickness

Product Standard: ASTM F891

Pipe Compound: ASTM D4396 Cell Class 11432

Certifications: ANSI/NSF Standard 61

ANSI/NSF Standard 14

End Finish: Plain End or Belled End

Pipe Length: 10 or 20 feet overall

Installation: JM Eagle™ Installation Guide

SOLVENT WELD

SUBMITTAL AND DATA SHEET



PVC SOLVENT WELD - (SCHEDULE SERIES)

Dual marking for both Pressure and Drain, Waste, Vent (DWV) Applications

JM EAGLE™ PVC SCHEDULE 40/DWV PIPE

Specifications: ASTM D1785 & ASTM D2665 : :

Listed : ANSI/NSF-PW NSF-DWV
Standard 61, Standard 14

NOM. PIPE SIZE (IN)	O.D. (IN)	NOM. I.D. (IN)	MIN. T. (IN)	WATER PRESSURE RATING AT 23°C (73°F)	APPROX. WEIGHT (LBS/FT)
1/2	0.840	0.609	0.109	600	0.164
3/4	1.050	0.810	0.113	480	0.218
1	1.315	1.033	0.133	450	0.324
1-1/4	1.660	1.363	0.140	370	0.439
1-1/2	1.900	1.593	0.145	330	0.525
2	2.375	2.049	0.154	280	0.705
2-1/2	2.875	2.445	0.203	300	1.118
3	3.500	3.042	0.216	260	1.463
4	4.500	3.998	0.237	220	2.083
6	6.625	6.031	0.280	180	3.663
8	8.625	7.942	0.322	160	5.512
10	10.750	9.976	0.365	140	7.815
12	12.750	11.889	0.406	130	10.333
14	14.000	13.073	0.437	130	12.220
16	16.000	14.940	0.500	130	15.980

: : Standard Color: White, Standard Length 10' & 20', Plain End and Belled End
Purple color for reclaim, contact your sales rep for availability

JM EAGLE™ PVC SCHEDULE 80 PIPE

Specifications: ASTM D1785 : :

Listed : ANSI/NSF-PW Standard 61, Standard 14

NOM. PIPE SIZE (IN)	O.D. (IN)	NOM. I.D. (IN)	MIN. T. (IN)	WATER PRESSURE RATING AT 23°C (73°F)	APPROX. WEIGHT (LBS/FT)
1/2	0.840	0.528	0.147	850	0.210
3/4	1.050	0.724	0.154	690	0.285
1	1.315	0.936	0.179	630	0.419
1-1/4	1.660	1.255	0.191	520	0.579
1-1/2	1.900	1.476	0.200	470	0.701
2	2.375	1.913	0.218	400	0.969
2-1/2	2.875	2.290	0.276	420	1.479
3	3.500	2.864	0.300	370	1.979
4	4.500	3.786	0.337	320	2.892
6	6.625	5.709	0.432	280	5.516
8	8.625	7.565	0.500	250	8.336
10	10.750	9.493	0.593	230	12.375
12	12.750	11.294	0.687	230	17.027

: Standard Color: Dark Gray, Standard Length: 20' overall,
Plain End Only

† Available in Western Region Only.

I.D. : Inside Diameter

O.D. : Outside Diameter

T. : Wall Thickness

Product Standard: ASTM D1785 Pressure Pipe
Pipe Compound: ASTM D1784 Cell Class 12454
Installation: JM Eagle™ Installation Guide

SOLVENT WELD

SUBMITTAL AND DATA SHEET



JM EAGLE™ PVC SOLVENT WELD PRESSURE RATED PIPE

Specifications: ASTM D2241

Listed : ANSI/NSF - PW Standard 61, Standard 14

NOM. PIPE SIZE (IN)	O.D. (IN)	100 psi/ SDR 41 [†] MIN. T. (IN)	NOM. I.D. (IN)	125 psi/ SDR 32.5 [†] MIN. T. (IN)	NOM. I.D. (IN)	160 psi/ SDR 26 MIN. T. (IN)	NOM. I.D. (IN)
1/2	0.840	—	—	—	—	—	—
3/4	1.050	—	—	—	—	—	—
1	1.315	—	—	—	—	0.060	1.188
1-1/4	1.660	—	—	0.060	1.533	0.064	1.524
1-1/2	1.900	—	—	0.060	1.773	0.073	1.745
2	2.375	—	—	0.073	2.220	0.091	2.182
2-1/2	2.875	—	—	0.088	2.688	0.110	2.642
3	3.500	0.085	3.320	0.108	3.271	0.135	3.214
3-1/2	4.000	0.098	3.792	0.123	3.739	0.154	3.674
4	4.500	0.110	4.267	0.138	4.207	0.173	4.133
5	5.563	0.136	5.275	0.171	5.200	0.214	5.109
6	6.625	0.162	6.282	0.204	6.193	0.255	6.084
8	8.625	0.210	8.180	0.265	8.063	0.332	7.921
10	10.750	0.262	10.195	0.331	10.048	0.413	9.874
12	12.750	0.311	12.091	0.392	11.919	0.490	11.711

NOM. PIPE SIZE (IN)	O.D. (IN)	200 psi/ SDR 21 MIN. T. (IN)	NOM. I.D. (IN)	250 psi/ SDR 17 MIN. T. (IN)	NOM. I.D. (IN)	315 psi/ SDR 13.5 MIN. T. (IN)	NOM. I.D. (IN)
1/2	0.840	—	—	—	—	0.062	0.709
3/4	1.050	0.060	0.923	0.062	0.919	0.078	0.885
1	1.315	0.063	1.181	0.077	1.152	0.097	1.109
1-1/4	1.660	0.079	1.493	0.098	1.452	0.123	1.399
1-1/2	1.900	0.090	1.709	0.112	1.663	0.141	1.601
2	2.375	0.113	2.135	0.140	2.078	0.176	2.002
2-1/2	2.875	0.137	2.585	0.169	2.517	0.213	2.423
3	3.500	0.167	3.146	0.206	3.063	0.259	2.951
3-1/2	4.000	0.190	3.597	0.235	3.502	0.296	3.372
4	4.500	0.214	4.046	0.265	3.938	0.333	3.794
5	5.563	0.265	5.001	0.327	4.870	0.412	4.690
6	6.625	0.316	5.955	0.390	5.798	0.491	5.584
8	8.625	0.410	7.756	0.508	7.548	—	—
10	10.750	0.511	9.667	0.632	9.410	—	—
12	12.750	0.606	11.465	0.750	11.160	—	—

Product Standard: ASTM D2241 Pressure Pipe
 Pipe Compound: ASTM D1784 Cell Class 12454
 Certifications: ANSI/NSF Standard 61
 ANSI/NSF Standard 14
 End Finish: Plain End or Belled End
 Pipe Length: 20 feet overall
 Installation: JM Eagle™ Installation Guide

:: Standard Color: White, Standard Length: 20' Overall, Belled End Only.
 Purple color for reclaim, contact your sales rep for availability.
[†] Available in Western Region Only.
 * Prior to ordering or specifying, please consult JM Eagle™ for product and/or listing availability.

SOLVENT WELD

SUBMITTAL AND DATA SHEET

PERFORATED UNDERDRAIN PIPE : :

JM EAGLE™ PVC ASTM D3034 SOLVENT WELD SDR35 SEWER PIPE

JM EAGLE™ SOLVENT WELD SEWER PIPE CONFORMS TO SPECIFICATIONS PRIOR TO PERFORATION AND CELL CLASS 12454 OR 12364 AS DEFINED IN ASTM D1784

NOM. PIPE SIZE (IN)	O.D. (IN)	NOM. I.D. (IN)	MIN T. (IN)	APPROX. WEIGHT (LBS/FT)
4"	4.215	3.961	0.120	1.022
4" x 10' Perf	4.215	3.961	0.120	1.022
6"	6.275	5.893	0.180	2.285
6" x 10' Perf	6.275	5.893	0.180	2.285

- :: Standard Color: Green, Standard length: 10' or 20' Overall, Belled End Only
- :: Standard perforations for pipe are two rows of holes 1/2" in diameter on 5" centers and 120° angle apart.
- Perforated pipe does not have ASTM designation on print line.

When using JM Eagle™ PVC ASTM D3034 Solvent Weld Sewer Pipe for septic tank fields, please install in accordance with ASTM D2321, and JM Eagle™ Publication JME-05B, "Gravity Sewer Installation Guide."

JM EAGLE™ PVC ASTM D2729 SOLVENT WELD DRAIN PIPE

JM EAGLE™ SOLVENT WELD DRAIN PIPE CONFORMS TO SPECIFICATIONS AND CELL CLASS 12454 OR 12164 AS DEFINED IN ASTM D1784

NOM. PIPE SIZE (IN)	O.D. (IN)	NOM. I.D. (IN)	MIN T. (IN)	APPROX. WEIGHT (LBS/FT)
3" Solid	3.250	3.102	0.070	0.465
3" Perf	3.250	3.102	0.070	0.465
4" Solid	4.215	4.056	0.075	0.648
4" Perf	4.215	4.056	0.075	0.648
6" Solid	6.275	6.063	0.100	1.300
6" Perf	6.275	6.063	0.100	1.300

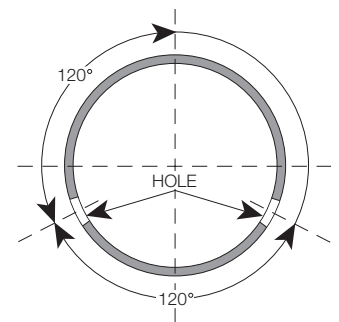

- :: Standard Color: White, Standard length: 10' Overall, Belled End Only
- :: Standard perforations for pipe are two rows of holes 1/2" in diameter on 5" centers and 120° angle apart.
- Three perforation rows may be available.

When using JM Eagle™ PVC ASTM D2729 Solvent Weld Drain Pipe for septic tank fields, please install in accordance with ASTM F481, and JM Eagle™ Publication JME-05B, "Gravity Sewer Installation Guide."

* Prior to ordering or specifying, please consult JM Eagle™ for product and /or listing availability.

I.D. : Inside Diameter
 O.D. : Outside Diameter
 T. : Wall Thickness

SOLVENT WELD

SUBMITTAL AND DATA SHEET

JM EAGLE™ SOLAR BLOK - UVR SCHEDULE 40 IPS SIZE

Specifications: ASTM D1785

Listed : ANSI/NSF 61

NOM. PIPE SIZE (IN)	O.D. (IN)	APPROX. I. D. (IN)	MIN. T. (IN)	PRESSURE RATING (psi)	APPROX. WEIGHT (LBS/FT)
1/2	0.840	0.609	0.109	600	0.164
3/4	1,050	0.810	0.113	480	0.218
1	1.315	1.033	0.133	450	0.324
1-1/4	1.660	1.363	0.140	370	0.439
1-1/2	1.900	1.593	0.145	330	0.525
2	2.375	2.049	0.154	280	0.705
2-1/2	2.875	2.445	0.203	300	1.118
3	3.500	3.042	0.216	260	1.463
4	4.500	3.998	0.237	220	2.083

Pipe color is beige.

Pipe is produced with integral Solvent Weld bells.

Available in 20 foot lengths only.

PVC material is specially formulated to increase resistance to ultraviolet rays.

The material includes the maximum amount of titanium dioxide allowed by the PPI PVC Range Composition for pressure pipe applications.