

JANUARY 2010

STANDARD PERFORATION PATTERN FOR EAGLE CORR PE™

STANDARD PERFORATION PATTERN

JM Eagle manufactures its 4-inch to 60-inch (100 mm to 1500 mm) diameter Eagle Corr PE pipe in accordance with AASHTO Class II perforation patterns and requirements. The perforations shall be

made in the valley of the pipe corrugation and shall be either slotted or circular. The perforation type, dimension, number of rows, pattern, and nominal water inlet area can be found in *Table 1* below.

Table 1

AASHTO CLASS II PERFORATION PATTERN						
NOMINAL ID IN (MM)	PERFORATION TYPE	LENGTH OR DIAMETER IN (MM)	WIDTH IN (MM)	NO. OF ROWS OF PERFORATIONS	PERFORATION PATTERN	NOMINAL WATER INLET AREA (IN ² /FT)
4 (100)	Slot	0.984 (25.00)	0.118 (2.88)	3	A	6.46
6 (150)	Slot	0.984 (25.00)	0.118 (2.88)	3	A	5.36
8 (200)	Slot	1.181 (30.00)	0.118 (2.88)	3	A	5.17
10 (250)	Slot	1.181 (30.00)	0.118 (2.88)	3	A	3.89
12 (300)	Circular	0.375 (9.53)	-	6	B	4.10
15 (375)	Circular	0.375 (9.53)	-	6	B	3.07
18 (450)	Circular	0.375 (9.53)	-	6	B	2.57
24 (600)	Circular	0.375 (9.53)	-	8	C	3.42
30 (750)	Circular	0.375 (9.53)	-	8	C	2.73
36 (900)	Circular	0.375 (9.53)	-	16	D	4.10
42 (1050)	Circular	0.375 (9.53)	-	16	D	4.10
48 (1200)	Circular	0.375 (9.53)	-	16	D	4.10
60 (1500)	Circular	0.375 (9.53)	-	16	D	2.73



Building essentials
for a better tomorrow™

CLASS II PERFORATION CONFIGURATIONS

Figure A:

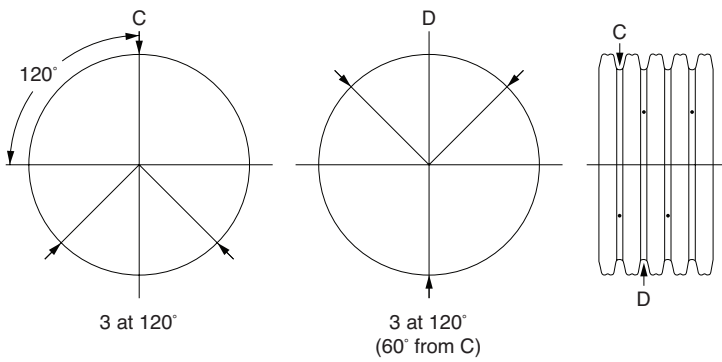

Figure B:

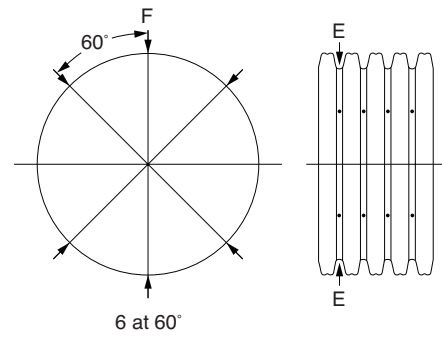

Figure C:

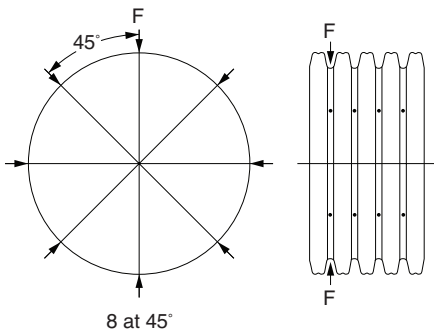

Figure D:

