



EAGLE GREEN PE™
MEETS ASTM SPECIFICATIONS



*Building essentials
for a better tomorrow™*



EAGLE GREEN PE™

Dual Wall Recycled-Material Drainage Pipe
(4-inch to 60-inch)
ASTM F2648

Single Wall Recycled-Material Drainage Pipe
(4-inch & 6-inch)
ASTM F405



EAGLE GREEN PE™

CONTENTS

01	PRODUCT DESCRIPTION	2
02	SHORT FORM SPECIFICATION	5
03	DIMENSIONS AND WEIGHTS	9
04	MINIMUM AND MAXIMUM BURIAL DEPTH RECOMMENDATIONS	11
05	INSTALLATION	14
06	SHORT FORM INSTALLATION GUIDE.	23
07	WARRANTY	24

01

PRODUCT DESCRIPTION

DESCRIPTION

Eagle Green PE™ pipe is available in 4-inch to 60-inch diameters and is suitable for use in gravity flow drainage applications. This product features a Corrugated exterior for structural strength and smooth interior for maximum hydraulic efficiency. Its superior strength-to-weight ratio and flexible conduit design mean it will support H-25 live loads with a minimum cover of 1 foot, while allowing for cover heights in excess of 100 feet.

APPLICATIONS

Typical applications for Eagle Green PE™ pipe include residential, commercial, recreational, agricultural and irrigation projects.



CORROSION RESISTANCE

HDPE is one of the most chemically inert plastics and therefore is extremely resistant to chemical attack and Corrosion. Corrugated HDPE pipe can resist the Corrosive effects of soils or effluents with pH range from a very acidic 1.5 to a very caustic 14. (See Graph 1.) Corrugated HDPE pipe is often specified where acidic or alkaline native soil conditions exist.

PH SERVICE RANGE

Graph 1

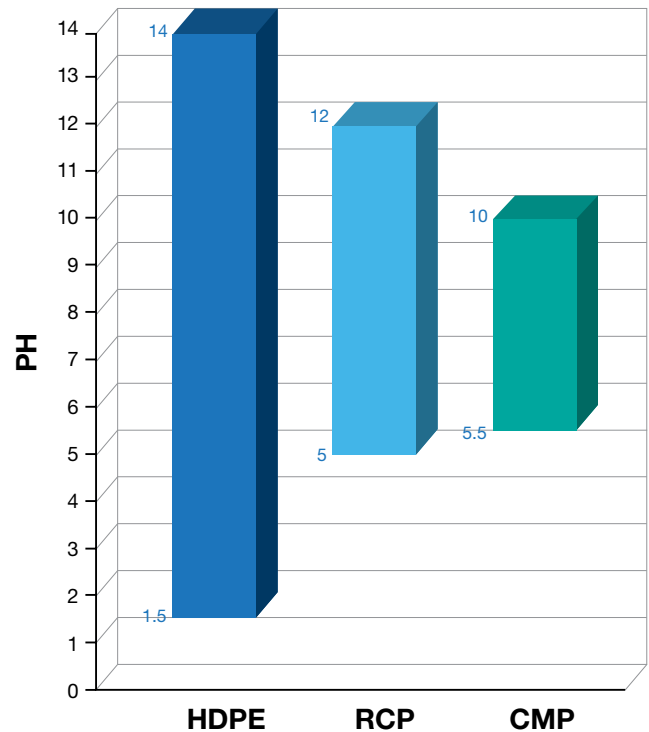

ABRASION RESISTANCE

HDPE's molecular structure and ductility result in excellent resistance to abrasion, gouging and scratching. Corrugated HDPE pipe is significantly more resistant to abrasion than RCP and CMP pipe. In fact, Corrugated HDPE pipe is frequently specified in mining applications to convey slurries containing highly abrasive mine tailings.



HYDRAULIC EFFICIENCY

Eagle Green PE™ (Dual Wall) pipe's 20-foot sections, smooth interior wall and precision-engineered joint tolerances provide a Manning's "n" coefficient of approx 0.010 to 0.012. By comparison, CMP has a Manning's "n" value of 0.023. (See Graph 2.) Using a conservative Manning's "n" value of 0.012 is suggested when performing hydraulic calculations to accommodate actual field conditions that might include debris and sedimentation.

DESIGN MANNINGS "n" VALUE Graph 2



WATERTIGHT JOINTS

Eagle Green PE™ (Dual Wall) pipe features a heavy duty integral bell and dual gasket spigot for a superior Corrugated HDPE watertight connection. (See Diagram 1.) Eagle Green PE's watertight joints are designed to achieve 10.8 psi when tested in the laboratory in accordance with ASTM D3212. Twenty-foot sections and watertight joints result in less chance for pipe infiltration.

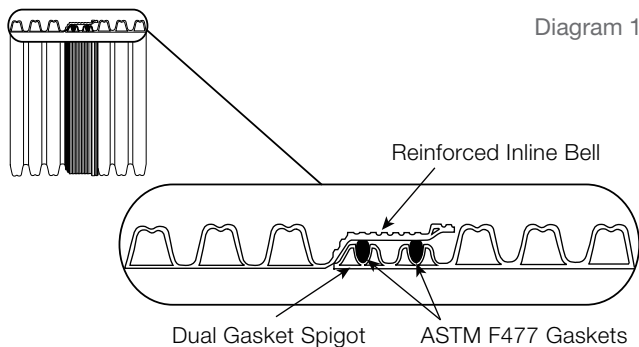

SERVICE LIFE

The service life of an underground conduit is the function of several variables including the pipe material properties, structural strength, proper installation, and long-term durability attributes. Corrugated HDPE pipe manufactured from the materials specified in ASTM D3350 is expected to significantly exceed 100 years. Flexible conduit design of the pipe allows for a long-term deflection of 5% to 7.5% without failure or damage.

DESIGN SERVICE LIFE Graph 3

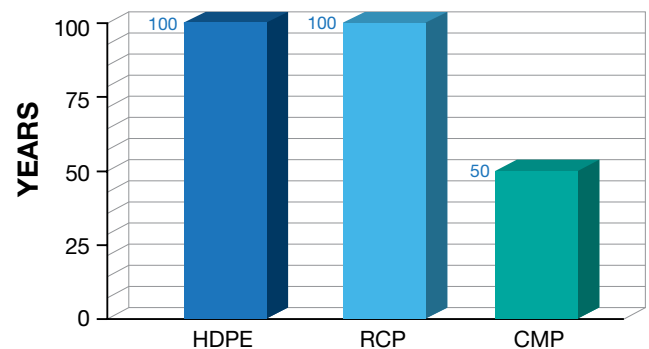



PRODUCT DESCRIPTION

(CONTINUED)

INSTALLATION EFFICIENCY & SAVINGS

Eagle Green PE™ (Dual Wall) pipe is approximately 30 times lighter than reinforced concrete pipe, making it easier to load, transport, handle and install. Corrugated HDPE pipe's 20-foot lay length vs. RCP pipe's 8-foot lay length translates into approximately 60% fewer joints per pipe run. The result is an increase in installation efficiency and a decrease in machinery and labor costs.

FULL LINE OF STANDARD AND CUSTOM FITTINGS

Eagle Green PE™ (Dual Wall) pipe is available with a full line of standard and custom fittings. Fittings can have either a soil tight or watertight (10.8 psi) joint connection. Eagle Green PE™ (Single Wall) pipe is available with a full line of standard soil tight fittings.



INSTALLATION

This product should be installed in accordance with ASTM D2321. Specific instructions for the installation of Eagle Green PE™ pipe can be found in Section 05 (Installation) of this brochure.



QUALITY CONTROL

Eagle Green PE™ (Dual Wall) pipe is manufactured and tested in accordance with ASTM F2648. Eagle Green PE™ (Single Wall) pipe is manufactured and tested in accordance with ASTM F405. All JM Eagle pipe products are subject to our extensive Quality Control/Quality Assurance protocol throughout every step of the manufacturing process. JM Eagle's Quality Management System is ISO 9001:2000 registered. Copies of the registration certificates are available on our Web site at www.jmeagle.com.

SHORT FORM SPECIFICATION

EAGLE GREEN PE™ (DUAL WALL)

SCOPE

This specification is for 4-inch to 60-inch Eagle Green PE™ (Dual Wall) pipe for use in gravity flow applications.

PIPE

Pipe shall have a corrugated exterior and a smooth interior with a Mannings “n” value of ≤ 0.012 . Pipe is manufactured in accordance with ASTM F2648. In addition, pipe shall have a reinforced bell with a dual-gasket spigot.

JOINTS

Pipe shall be joined together using an integral bell and spigot joint that meets the 10.8 psi watertight requirements of ASTM D3212.

GASKETS

Gaskets (electrometric seals) shall be in accordance with ASTM F477. Dual gaskets shall be installed by the manufacturer and covered by a protective wrap to protect the gasket from debris during shipping and storage. The manufacturer shall supply a joint lubricant to be used on the gasket during pipe assembly.



MATERIALS

Pipe and fittings shall be made out of high-density polyethylene resin that meets or exceeds the requirements of ASTM D3350. Pipe shall contain a minimum of 2% Carbon Black content per ASTM D3350.

FITTINGS

Fittings shall be in accordance with AASHTO M252, AASHTO M294, ASTM F2306 and ASTM F2648. Watertight fittings shall provide a joint that meets the watertight requirements of ASTM D3212. To insure compatibility in the field, the pipe manufacturer shall provide all fittings.



INSTALLATION

Pipe installation shall be in accordance with ASTM D2321 and JM Eagle’s recommended installation guidelines. Minimum cover for 4-inch to 48-inch (100 mm to 1,200 mm) diameters shall be at least 1 foot. Minimum cover for 60-inch (1,500 mm) diameter pipe shall be at least 2 feet. Specific instructions for the installation of Eagle Green PE™ pipe can be found in Section 05 (Installation) of this brochure.



SHORT FORM SPECIFICATION

EAGLE GREEN PE™ (DUAL WALL)

(CONTINUED)

APPLICABLE ASTM & AASHTO STANDARDS

SPECIFICATION	DESCRIPTION
ASTM D3350	Standard Specification for Polyethylene Plastics Pipe and Fittings Materials
ASTM D1238	Standard Test Method for Melt Flow Rates of Thermoplastics by Extrusion Plastometer
ASTM D4218	Standard Test Method for determination of Carbon Black Content in Polyethylene Compounds by Muffle-Furnace Technique
ASTM F477	Elastomeric Seals (Gaskets) for Joining Plastic Pipe
ASTM D2444	Standard Test Method for Determination of the Impact Resistance of Thermoplastic Pipe and Fittings by Means of a Tup (Falling Weight)
ASTM D2412	Standard Test Method for Determination of External Loading Characteristics of Plastic Pipe by Parallel-Plate Loading
ASTM D3212	Joints for Drain and Sewer Plastic Pipes Using Flexible
ASTM D2321	Underground Installation of Thermoplastic Pipe for Sewers and Other Gravity Flow Applications
AASHTO Section 30	Construction Standard for Thermoplastic Pipe
ASTM F2487	Standard Practice for Infiltration and Exfiltration Acceptance Testing of Installed Greenugated High Density Polyethylene Pipelines
ASTM F1417	Standard Test Method for Installation Acceptance of Plastic Gravity Sewer Lines Using Low-Pressure Air
ASTM F2648	Standard specification for 2-inch to 60-inch (50 mm to 1,500 mm) annular corrugated profile wall polyethylene pipe and fittings for land drainage applications.



SHORT FORM SPECIFICATION

EAGLE GREEN PE™ (SINGLE WALL)

SCOPE

This specification is for 4-inch and 6-inch Eagle Green (Single Wall) PE pipe for use in gravity flow applications.

PIPE

Pipe shall have a Greenugated, annular exterior and interior. 4-inch and 6-inch pipe shall be manufactured in accordance with ASTM 405.

JOINTS

Pipe shall be joined together using snap and/or split couplers in accordance with ASTM 405.



MATERIALS

Pipe and fittings shall be made out of high-density polyethylene resin that meets or exceeds the requirements of ASTM D3350. Pipe shall contain a minimum of 2% Carbon Black content per ASTM D3350.

FITTINGS

Fittings shall be in accordance with AASHTO M252.

INSTALLATION

Pipe installation shall be in accordance with ASTM D2321 and JM Eagle's recommended installation guidelines. Minimum cover for 4 inch and 6 inch (100 mm to 1200 mm) diameters shall be at least 1 foot. Specific instructions for the installation of Eagle Green PE™ pipe can be found in Section 05 (Installation) of this brochure.



SHORT FORM SPECIFICATION

EAGLE GREEN PE™ (SINGLE WALL)

(CONTINUED)

APPLICABLE ASTM & AASHTO STANDARDS

SPECIFICATION	DESCRIPTION
ASTM D3350	Standard Specification for Polyethylene Plastics Pipe and Fittings Materials
ASTM D1238	Standard Test Method for Melt Flow Rates of Thermoplastics by Extrusion Plastometer
ASTM D1603	Standard Test Method for Carbon Black Content in Olefin Plastics
ASTM D2444	Standard Test Method for Determination of the Impact Resistance of Thermoplastic Pipe and Fittings by Means of a Tup (Falling Weight)
ASTM D2412	Standard Test Method for Determination of External Loading Characteristics of Plastic Pipe by Parallel-Plate Loading
ASTM D2321	Underground Installation of Thermoplastic Pipe for Sewers and Other Gravity Flow Applications
AASHTO Section 30	Construction Standard for Thermoplastic Pipe
ASTM F405	ASTM F405 Standard Specification for corrugated polyethylene pipe and fittings.

DIMENSIONS AND WEIGHTS

SUBMITTAL AND DATA SHEET

EAGLE GREEN PE™ (DUAL WALL)

THIS SPECIFICATION REFERS TO 4"-60" PIPE FOR USE IN GRAVITY FLOW DRAINAGE APPLICATIONS.

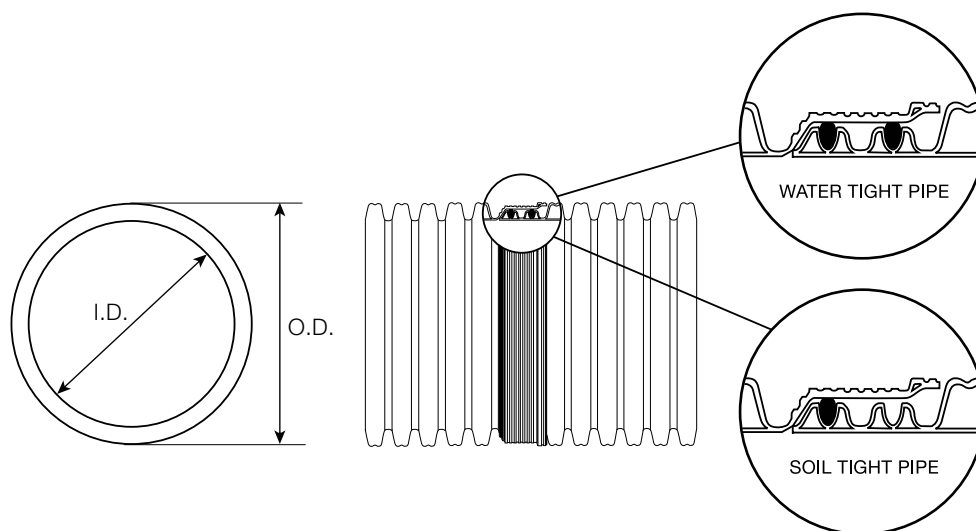

NOMINAL I.D. IN (MM)	APPROX. O.D. IN (MM)	LAYING LENGTH (FT)	PIPE STIFFNESS PSI	AVERAGE UNIT WEIGHT LB/FT
4 (100)	5 (120)	20	50	0.4
6 (150)	7 (174)	20	50	1.1
8 (200)	9 (231)	20	50	1.7
10 (250)	11 (290)	20	50	2.5
12 (300)	14 (363)	20	50	3.2
15 (375)	17 (444)	20	42	4.8
18 (450)	21 (529)	20	40	6.3
24 (600)	28 (699)	20	34	11.2
30 (750)	35 (880)	20	28	15.8
36 (900)	42 (1055)	20	22	20.9
42 (1050)	47 (1204)	20	20	26.9
48 (1200)	54 (1367)	20	18	34.0
60 (1500)	67 (1693)	20	14	56.0

PRODUCT STANDARD: ASTM F2648

PIPE COMPOUND: ASTM D3350

GASKET: ASTM F477

JOINT PERFORMANCE: ASTM D3212

INSTALLATION: ASTM D2321; Eagle Corr PE Installation Guide



DIMENSIONS AND WEIGHTS

(CONTINUED)

EAGLE GREEN PE™ (SINGLE WALL)

THIS SPECIFICATION REFERS TO 4" AND 6" PIPE FOR USE IN GRAVITY FLOW DRAINAGE APPLICATIONS.

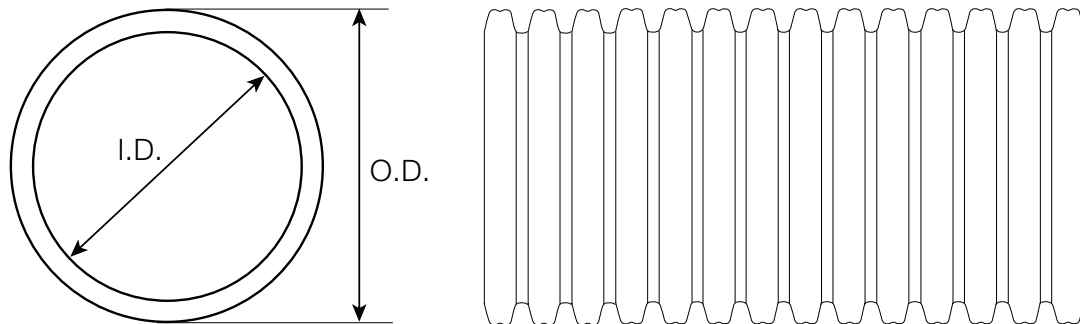

NOMINAL I.D. IN (MM)	APPROX. O.D. IN (MM)	LAYING LENGTH (FT)	PIPE STIFFNESS PSI	AVERAGE UNIT WEIGHT LB/FT
4 (100)	5 (120)	100/250/3000	36	0.35
6 (150)	7 (174)	100/1400	36	0.90

PRODUCT STANDARD: ASTM F405
 PIPE COMPOUND: ASTM D3350
 INSTALLATION: ASTM D2321; Eagle Corr PE Installation Guide

MINIMUM AND MAXIMUM BURIAL DEPTH RECOMMENDATIONS

MINIMUM COVER HEIGHT

Minimum cover height for 4-inch to 48-inch (100 mm to 1,200 mm) diameters shall be at least 1 foot. Minimum cover height for 60-inch (1,500 mm) diameter pipe shall be at least 2 feet. Minimum cover height is measured from the crown of the pipe to the bottom of a flexible pavement section or to the top of a rigid pavement section. In addition to the minimum cover height requirements, an extra foot of temporary cover is recommended where heavy-duty construction equipment may travel over the pipe during the construction phase of the project.

TABLE 1

MINIMUM COVER HEIGHTS	
NOMINAL ID IN (MM)	MINIMUM COVER FT (M)
ID ≤ 48" (1200)	1 (0.3)
Id = 60 (1500)	2 (0.6)

BURIAL DEPTH RECOMMENDATIONS

The information contained herein describes the maximum allowable cover height for Eagle Green PE™ (Dual Wall). These recommendations address maximum burial depths for pipe meeting the requirements of AASHTO M252 Type S, M294 Type S, ASTM F2306 and ASTM F2648. This analysis is based on the design method developed by the Plastic Pipe Institute. The PPI design method is based on the actual pipe Greenugation profile, which is conservative as evidenced by a long history of analytically predicted burial depths matching successful field installations.

MAXIMUM COVER HEIGHT ANALYSIS

The type and compaction of backfill around the pipe significantly influence the maximum burial depth. The influence of the backfill and compaction is illustrated in Table 2 below. Table 2 was developed assuming the pipe is installed in accordance with ASTM D2321. These maximum cover height recommendations assume the native soil is of adequate strength and is suitable for installation. Additionally the calculations assume no hydrostatic load and soil density of 120 pounds per cubic feet. Detailed calculations for each of the conditions described in Table 2 are available upon request.





MINIMUM AND MAXIMUM BURIAL DEPTH RECOMMENDATIONS

(CONTINUED)

TABLE 2

MAXIMUM COVER PPI DESIGN METHOD (FT)								
DIAMETER IN (MM)	CLASS 1		CLASS 2			CLASS 3		
	COMPACTED	DUMPED	95%	90%	85%	95%	90%	85%
4 (100)	60	20	40	28	20	28	21	19
6 (150)	63	22	43	30	22	31	23	21
8 (200)	61	20	41	28	20	29	21	19
10 (250)	61	20	40	28	20	28	21	19
12 (300)	55	17	35	24	17	25	18	16
15 (375)	55	17	35	24	17	24	18	15
18 (450)	53	16	34	23	16	23	17	14
24 (600)	54	16	34	23	16	24	17	14
30 (750)	51	14	32	21	14	22	15	13
36 (900)	49	13	31	20	13	21	14	12
42 (1050)	48	13	31	20	13	21	14	12
48 (1200)	48	13	30	20	13	20	14	11
60 (1500)	50	13	31	20	13	21	14	12

Notes:

1. Backfill material classes are based on backfill material as described and defined in ASTM D2321.
2. All compaction levels are based on standard proctor density.
3. Compaction and backfill material should be uniform throughout the backfill zone.
4. Backfill material and compaction levels (not shown in Table 1) may be acceptable; however special designs must be approved by JM Eagle or an engineer.
5. Deeper burial depths may be obtained by consulting an engineer for special designs.



PIPE PROPERTIES

Key pipe profile properties that influence the performance of the soil/pipe structure interaction include the moment of inertia of the profile (I), distance from the inside diameter to the neutral axis (c), and the section area of a longitudinal profile section (A_s). Pipe stiffness (PS) is also important criteria. The minimum pipe stiffness, defined by AASHTO was used for this analysis. These key properties are summarized in Table 3 below:

TABLE 3

SECTION PROPERTY SUMMARY						
NOMINAL INSIDE DIAMETER (IN)	OUTSIDE DIAMETER (IN)	PIPE STIFFNESS, PS (PSI)	CROSS SECTIONAL AREA, A_s (IN ² /IN)	DISTANCE FROM INSIDE DIAMETER TO NEUTRAL AXIS, C (IN)	MOMENT OF INERTIA, I (IN ⁴ /IN)	PITCH (IN)
4.0	4.7	50	0.076	0.14	0.0012	0.65
6.0	6.9	50	0.122	0.19	0.0037	0.78
8.0	9.1	50	0.146	0.28	0.0085	0.97
10.0	11.4	50	0.180	0.33	0.0171	1.29
12.0	14.3	50	0.183	0.47	0.0366	1.94
15.0	17.5	42	0.222	0.51	0.0549	2.59
18.0	20.8	40	0.244	0.58	0.0824	3.10
24.0	27.5	34	0.330	0.72	0.1593	3.10
30.0	34.6	28	0.370	0.95	0.3118	3.88
36.0	41.5	22	0.410	1.12	0.4986	5.17
42.0	47.4	20	0.448	1.18	0.5531	5.17
48.0	53.8	18	0.498	1.21	0.6551	5.17
60.0	66.7	14	0.660	1.44	1.2766	7.76

Notes:

1. Section property data is considered conservative however properties may change based on actual production dimensions.

05

INSTALLATION

PIPE ZONE TERMINOLOGY

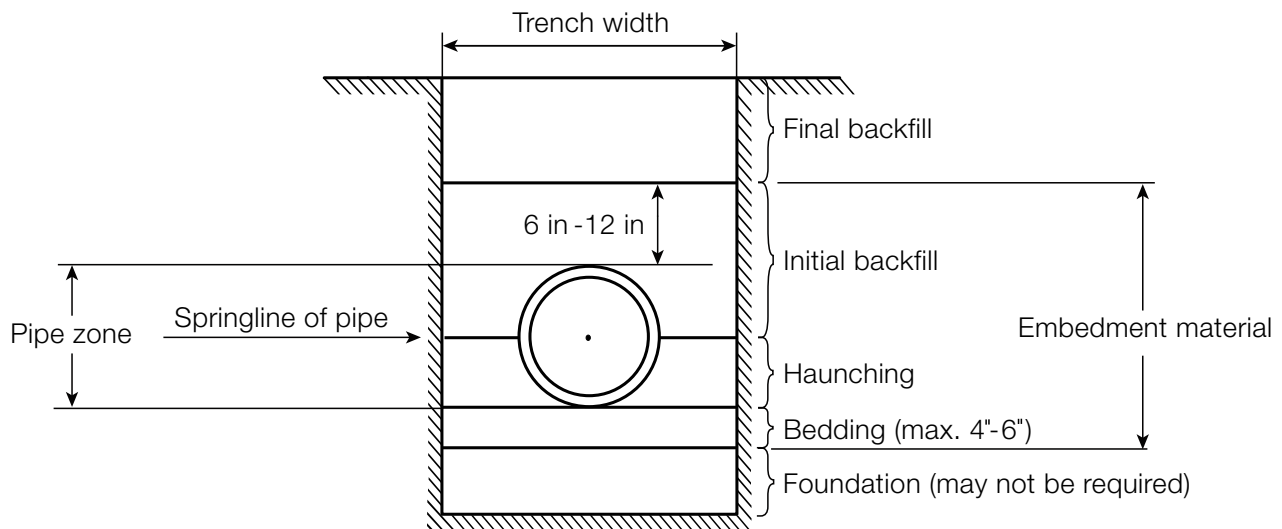

PREPARATION OF THE TRENCH BOTTOM

The trench floor should be constructed to provide a firm, stable and uniform support for the full length of the pipe. This can be accomplished by bringing the entire trench floor to a level grade to permit proper joint assembly, alignment, and support. Portions of the trench that are excavated below grade should be returned to grade and compacted as required to provide proper support. If the native trench soil is not suitable for the pipe bedding, the trench should be over excavated and refilled with suitable foundation material as specified by the engineer. A cushion of acceptable bedding material should always be provided between any hard foundation and the pipe. Large rocks, boulders, and stones should be removed to allow a minimum of 4 inches of soil cushion on all sides of the pipe and accessories.

TRENCH EXCAVATION

The minimum width of a trench to insure the proper installation of a buried conduit depends on the pipe diameter, embedment material and compaction requirements. Trench widths for small diameter pipes are typically deter-

mined by standard excavator bucket sizes. Trenches that are too narrow do not allow for the proper amount and compaction of embedment material in the haunch zones, while trenches that are too wide result in unnecessary costs. Recommended minimum trench widths per ASTM D2321 are shown in Table 4.

PIPE LAYING

Proper implements, tools and equipment should be used for placement of the pipe in the trench to prevent damage. Avoid dropping pipe and accessories into the trench, as this may cause damage that is not easily detected. Additional handling instructions may be sought from our product installation guides or by contacting JM Eagle™. In general, pipe laying should begin at the lowest point and work toward manholes, service branches or clean-outs. Pipe bells can be laid in either direction, upstream or downstream without any significant hydraulic loss. However, common practice is to lay the bells in the direction of work progress to ease installation. Additionally, by inserting the spigot into the bell rather than pushing the bell over the spigot, the risk of soil or



rubble being scooped under the gasket is reduced. If pipe laying is interrupted or halted, the exposed ends of the pipeline should be closed to prevent the entrance of trench water, mud and foreign matter.

BEDDING

Bedding is required primarily to bring the trench bottom up to grade. Bedding materials should be placed to provide uniform longitudinal support under the pipe to prevent low spots. Blocking should not be used to bring the pipe to grade. Under normal circumstances a bedding of 4 inches to 6 inches is sufficient. The middle one-third of the pipe OD should be loosely placed, while the remainder shall be compacted to a minimum 90% of Standard Proctor density.

HAUNCHING

The most important factor in assuring proper pipe-soil interaction is the haunching material and its density. This material provides the majority of the support that the pipe requires to function properly in regards to performance and deflection. This material should be placed and consolidated under the pipe haunches, the area of the pipe between the springline and the bottom of the pipe, to provide adequate side support to the pipe. In doing so, proper control should be exercised to avoid vertical and horizontal displacement of the pipe from proper alignment. If the bedding material is coarse and contains voids, the same coarse material should also be used for the haunching. In order for the haunching to provide adequate support, it must be consolidated at regular intervals to the springline of the pipe.

INITIAL BACKFILL

This portion of the pipe embedment begins at the springline of the pipe and extends to 6 inches to 12 inches above the top of the pipe. Since little to no side support is derived from the soils placed in this area, native soils may be used without any special compaction efforts. However,

if other structures are present, including roadways or buildings, their foundation requirements may require that this soil be consolidated. The main purpose of the placement of this native material is to protect the pipe from contact with falling rocks or other impact loads that may occur when the final backfill is applied.

For pipe buried under traffic bearing surfaces it is recommended that a minimum of 95% Proctor density be achieved from the bottom of the trench up to the road surface using Class I or Class II materials as described in Tables 6, 7 and 8.





INSTALLATION

(CONTINUED)

FINAL BACKFILL

The material used in the final backfilling of the trench need not be as carefully selected as the bedding, haunching, and initial backfill, with the exception of where this material is going to be in the zone of influence of the foundation for some present or future structure. In the final backfill material the following items should be avoided: boulders, frozen clumps of dirt, and rubble that could cause damage to the pipe.

Unless otherwise specified, the final backfill material should be placed using special compaction under improved surfaces and shoulders of streets, roads, aprons, curbs, and walks. Under open fields, lawns, wide shoulders, unimproved right-of-way, or neutral grounds free of traffic, final backfill should be placed using natural compaction. Special compaction requirements should be defined by the design engineer.



MINIMUM COVER

Minimum cover for diameter pipe shall be 1 foot from the crown of the pipe to the top of a rigid pavement section or to the bottom of a flexible pavement section. For 60-inch diameter pipe, the minimum cover shall be increased to 2 feet.

PARALLEL PIPE INSTALLATION

Storm sewer conduits and underground drainage systems can be installed in parallel pipe configurations provided that the haunch zones are compacted with the proper amount and type of embedment material. Class I, II, and III materials are suitable for foundation and embedment. Minimum spacing between parallel pipes shall meet the minimum criteria set forth in Table 5.

EMBEDMENT MATERIALS

Materials suitable for foundation and embedment are classified in the Tables 6 and 7. They include a number of processed materials plus soil types defined according to the Unified Soil Classification System (USCS) in ASTM D2487, "Standard Method for Classification of Soils for Engineering Purposes." Table 3 provides recommendations on the installation and use based on class of soil or aggregates and location within the trench. It is important to engineer all materials used in the pipe trench to work together and with the native material surrounding the trench.

CLASS IA MATERIALS

Class IA materials provide the maximum stability and pipe support for a given density because of the angular interlocking of the material particles. With minimum efforts, these materials can be installed at relatively high densities over a wide range of moisture contents. These materials also have excellent drainage characteristics that may aid in the control of water. These soils are often desirable as embedment in rock cuts where water is frequently encountered. On the other hand, when ground



water flow is anticipated, consideration should be given to potential migration of fines from adjacent materials into the open graded Class IA materials.

CLASS IB MATERIALS

These materials are produced by mixing Class IA and natural or processed sands to produce a particle-size distribution that minimizes migration from surrounding soils that may contain fines. They are more widely graded than Class IA and thus require more compaction effort to achieve the minimum density specified. When these materials are properly compacted, these soils exhibit high stiffness and strength, and depending on the amount of fines, may be relatively free draining.

CLASS II MATERIALS

When Class II materials are compacted they provide a relatively high level of pipe support. In most respects, they all have the desirable characteristics of Class IB materials when widely graded. However, open-graded groups may allow for migration and the sizes should be checked for compatibility with the native trench materials. Typically, Class II materials consist of rounded particles and are less stable than the angular materials of Class IA and IB, unless they are confined and compacted.

CLASS III MATERIALS

These materials provide less support for a given density than Class I or Class II materials. High levels of compactive effort are required if moisture content is not controlled. These materials will provide reasonable support once proper compaction is achieved.

CLASS IV-A MATERIALS

Class IV-A materials are not recommended as suitable embedment material and must be carefully evaluated by a geotechnical engineer before use. The moisture content of

the materials must be near optimum to minimize compactive effort and achieve the required density. Properly placed and compacted, these soils can provide reasonable levels of pipe support. However, these materials may not be suitable under high fills, surface applied dynamic loads, or under heavy vibratory compactors and tampers. These materials should be avoided if water conditions in the trench may cause instability and result in uncontrolled water content.



MIGRATION

In soils where ground water fluctuations occur, coarse or open-graded material placed adjacent to a finer material may be infiltrated by those fines. Such hydraulic gradients may arise during trench construction when water levels are being controlled by various pumping or well-pointing methods, or after construction when permeable under



INSTALLATION

(CONTINUED)

drain or embedment materials act as a “French” drain under high groundwater levels. Downward percolation of surface water may carry fine materials down into more coarse, open-graded bedding materials if the trench is not properly designed and constructed. The gradation and relative particle size of the embedment and adjacent materials must be compatible in order to minimize migration. As a general precaution, it is recommended that if significant groundwater flow is anticipated, avoid placing coarse, open-graded materials adjacent to finer materials, unless methods are employed to impede migration, such as the use of an appropriate stone filter or fabric along the boundary of incompatible materials.

EMBEDMENT COMPACTION

The moisture content of embedment materials must be maintained within suitable limits to permit placement and compaction to required levels without exhaustive efforts. For non-free draining soils, such as Class III and IV-A, moisture content should be held close to optimum. If water exists in the trench, free-draining embedment materials are generally more suitable because they are

more readily densified when saturated. Maximum particle size for embedment material is limited to only those materials passing a 1.5-inch (38 mm) sieve.

When using mechanical compactors, avoid contact with the pipe. When compacting over the pipe crown, a minimum of 6 inches of cover should be maintained when using small compactors. If larger compactors are used, the engineer should be consulted to specify the minimum distance from the pipe crown. This decision will be based on the depth of influence of the specific compaction equipment being used. For compaction by a hydro-hammer, a minimum of a 36 inches over the pipe crown is required. Heavy wheel loading or hydro-hammer methods should not be used in shallow applications where total cover is less than the influence zone of the compaction device. In shallow cover applications, materials requiring little or no mechanical compaction should be used for embedment of the pipe. The effectiveness of the compaction equipment necessary to achieve desired densities for specific types of materials depends on the chosen methods ability to deliver compactive energy. Coarse-grained, clean materials are free flowing and may not require mechanical compaction in some installations. These materials are more readily compacted using vibratory equipment. Fine materials with high plasticity may require kneading and impact force along with controlled water content to reach acceptable densities. In pipe trenches, small hand-held, or walk behind compactors, work well, not only to prevent pipe damage, but to insure thorough compaction in the confined spaces around the pipe and along the trench wall.



SHEETING

If soil conditions or regulations require the use of sheeting or boxes, they should be used in a manner so as not to disturb the haunching material within one pipe diameter on each side of pipe.



TABLE 4

MINIMUM TRENCH WIDTHS		
NOMINAL ID IN (MM)	AVERAGE OD IN (MM)	MINIMUM TRENCH WIDTH ¹ IN (M)
4 (100)	5 (120)	21 (0.5)
6 (150)	7 (174)	23 (0.6)
8 (200)	9 (231)	25 (0.6)
10 (250)	11 (290)	27 (0.7)
12 (300)	14 (363)	30 (0.8)
15 (375)	17 (444)	34 (0.9)
18 (450)	21 (529)	38 (1.0)
24 (600)	28 (699)	46 (1.2)
30 (750)	35 (880)	55 (1.4)
36 (900)	42 (1055)	64 (1.6)
42 (1050)	47 (1204)	71 (1.8)
48 (1200)	54 (1367)	79 (2.0)
60 (1500)	67 (1693)	95 (2.4)

¹ Minimum trench width per ASTM D2321 = greater of OD + 16" or 1.25 × OD + 12".

TABLE 5

PARALLEL PIPE INSTALLATION MINIMUM SPACING	
NOMINAL ID IN (MM)	MINIMUM SPACING IN (MM)
ID ≤ 24 (600)	12 (300)
ID > 24 (600)	ID/2

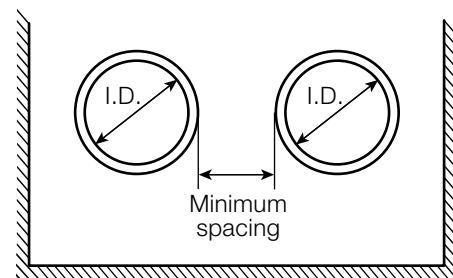

INSTALLATION

(CONTINUED)

TABLE 6

Description of Material Classification as Defined in ASTM D2321

CLASS	TYPE	SOIL SYMBOL GROUP	DESCRIPTION ASTM D2487	PERCENTAGE PASSING SIEVE SIZES .075MM			ATTERBERG LIMITS		COEFFICIENTS	
				1.5 IN (40 MM)	NO. 4 (4.75 MM)	NO. 200 (0.75 MM)	LL	PL	UNIFORMITY CU	CURVATURE C _c
IA	Manufactured Aggregates: open graded clean	none	Angular, crushed stone or rock, crushed slag, cinders or shell large void content, contain little or no fines	100%	< or = 10%	< 5%	Non Plastic	—	—	—
IB	Manufactured, Processed Aggregates: dense graded, clean	none	Angular, crushed stone (or other Class IA materials) and stone/sand mixtures with gradations selected to minimize migration of adjacent soils; contain little to no fines	100%	< or = 50%	< 5%	Non Plastic	—	—	—
II	Coarse-Grained Soils, clean	GW	Well-graded gravels and gravel-sand mixtures; little to no fines	100%	< 50% of coarse fraction	< 5%	Non Plastic	—	> 4	1 to 3
		GP	Poorly-graded gravels and gravel-sand mixtures; little to no fines	—	—	—	—	—	< 4	< 1 or > 3
		SW	Well-graded sands and gravelly sands; little to no fines	—	> 50% of coarse fraction	—	—	—	> 6	1 or 3
		SP	Poorly-graded sands and gravelly sands; little to no fines	—	—	—	—	—	< 6	< 1 or > 3
	Coarse-Grained Soils: borderline clean to w/fines		Sands and gravels which are borderline between clean and with fines	100%	varies	5% to 12%	Non Plastic	—	—	Same as for GW, GP, SW, and SP
III	Coarse-Grained Soils w/fines	GM	Silty gravels, gravel-sand-silt mixtures	100%	> 50% of coarse fraction	> 12% to < 50%	—	< 4 or < "A" Line	—	—
		GC	Clayey gravels, gravel-sand-clay mixtures	—	—	—	—	< 7 and > "A" Line	—	—
		SM	Silty sands, sand-silt mixtures	—	> 50% of coarse fraction	—	—	> 4 or < "A" Line	—	—
		SC	Clayey sands, sand-silt mixtures	—	—	—	—	> 7 and > "A" Line	—	—
IVA	Fine-Grained Soils: Inorganic	ML	Inorganic silts and very fine sands, rock flour, silty or clayey fine sands, silts with slight plasticity	100%	100%	> 50%	< 50	< 4 or < "A" Line	—	—
		CL	Inorganic clays of low to medium plasticity, gravelly clays, sandy clays, silty clays, lean clays	—	—	—	—	> 7 and > "A" Line	—	—
IVB	Fine-Grained Soils: Inorganic	MH	Inorganic silts, micaceous or diatomaceous fine sandy or silty soils, elastic silts	100%	100%	> 50%	> 50	< "A" Line	—	—
		CH	Inorganic clays of high plasticity, fat clays	—	—	—	—	> "A" Line	—	—
V	Organic Soils	OL	Organic silts and organic silty clays of low plasticity	100%	100%	> 50%	< 50	< 4 or < "A" Line	—	—
		OH	Organic clays of medium to high plasticity organic silts	—	—	—	> 50	< "A" Line	—	—
	Highly Organic	PT	Peat and other high organic soils	—	—	—	—	—	—	—



TABLE 7

Recommendations for Installation and Use of Soils and Aggregates for Foundation, Embedment and Backfill.

	SOIL CLASS AS DEFINED IN TABLE 1.1				
	CLASS IA	CLASS IB	CLASS II	CLASS III	CLASS IV-A
General Recommendations and Restrictions	Do not use where conditions may cause migration of fines from adjacent soil and loss of pipe support. Suitable for use as a drainage blanket and underdrain in rock cuts where adjacent material is suitably graded.	Process materials as required to obtain gradation which will minimize migration of adjacent materials. Suitable for use as drainage blanket and underdrain.	Where hydraulic gradient exist check gradation to minimize migration. "Clean" groups suitable for use as drainage blanket and underdrain.	Do not use where water conditions in trench may cause instability.	Obtain geotechnical evaluation of processed material. May not be suitable under high earth fills and surface applied loads or under heavy vibratory compactors and tampers. Do not use where water conditions in trench may cause instability.
Foundation	Suitable as foundation and for replacing over-excavated and unstable trench bottom as restricted above. Install and compact in 6-inch maximum layers.	Suitable as foundation and for replacing over-excavated and unstable trench bottom. Install and compact in 6-inch maximum layers.	Suitable as foundation and for replacing over-excavated and unstable trench bottom as restricted above. Install and compact in 6-inch maximum layers.	—	Suitable only in undisturbed conditions and where trench is dry. Remove all loose material and provide firm, uniform trench bottom before bedding is placed.
Bedding	Suitable as restricted above. Install in 6-inch maximum layers. Level final grade by hand. Minimum depth 4 inches (6 inches in rock cuts).	Install and compact in 6-inch maximum layers. Level final grade by hand. Minimum depth 4 inches (6 inches in rock cuts).	Suitable as restricted above. Install and compact in 6-inch maximum layers. Level final grade by hand. Minimum depth 4 inches (6 inches in rock cuts).	Suitable only in dry trench conditions. Install and compact in 6-inch maximum layers. Level final grade by hand. Minimum depth 4 inches (6 inches of rock cuts).	Suitable only in dry trench conditions and when optimum placement and compaction control is maintained. Install and compact in 6-inch maximum layers. Level final grade by hand. Minimum depth 4 inches (6 inches in rock cuts).
Haunching	Suitable as restricted above. Install in 6-inch maximum layers. Work in around pipe by hand to provide uniform support.	Install and compact in 6-inch maximum layers. Work in around pipe by hand to provide uniform support.	Suitable as restricted above. Install and compact in 6-inch maximum layers. Work in around pipe by hand to provide uniform support.	Suitable as restricted above. Install and compact in 6-inch maximum layers. Work in around pipe by hand to provide uniform support.	Suitable only in dry trench conditions and when optimum placement and compaction control is maintained. Install and compact in 6-inch maximum layers. Work in around pipe by hand to provide uniform support.
Initial Backfill	Suitable as restricted above. Install to a minimum of 6 inches above pipe crown.	Install and compact to a minimum of 6 inches above pipe crown.	Suitable as restricted above. Install and compact to a minimum of 6 inches above pipe crown.	Suitable as restricted above. Install and compact to a minimum of 6 inches above pipe crown.	Suitable as restricted above. Install and compact to a minimum of 6 inches above pipe crown.
Final Backfill	Compact as required by the engineer.	Compact as required by the engineer.	Compact as required by the engineer.	Compact as required by the engineer.	Suitable as restricted above. Compact as required by the engineer.

INSTALLATION

(CONTINUED)

TABLE 8

Provides an approximate guide to obtainable densities of various soils by several compaction methods. Minimum densities required will depend on the depth of cover, pipe stiffness and type of soil used. In most situations, the project engineer will determine the appropriate values during the design.

ESTIMATED RANGE OF COMPACTION BY EMBEDMENT CLASS AND METHOD				
Class of Embedment	I	II	III	IV
Material Description	Manufactured Granular Materials	Sand and Gravel, clean	Mixed-Grain	Fine-Grain
Optimum Moisture Content Range % of dry weight	—	9 to 12	9 to 18	6 to 30
Soil Consolidation Method	% OF PROCTOR (OR RELATIVE) DENSITY RANGE			
Power Tamper or Rammer	95-100 (75-100)	95-100 (80-100)	95-100	90-100
Portable Vibrator	80-95 (60-75)	80-95 (60-80)	80-95	75-90
Consolidation by Saturation	80-95 (60-75)	80-95 (60-80)	—	—
Hand Place	60-80 (40-60)	—	—	—
Hand Tamp	—	60-80 (50-60)	60-80	60-75
Dump	60-80 (40-60)	60-80 (50-60)	60-80	60-75

* For data, sizes or classes not reflected in these charts, please contact JM Eagle™ for assistance.

SHORT FORM INSTALLATION GUIDE

This information is furnished in order to provide a brief review of the installation requirements for JM Eagle's Eagle Green PE™ pipe. It is not intended to serve as or replace the FULL VERSION of the complete product installation guide available upon request.

EAGLE GREEN PE (DUAL WALL) INSTALLATION INSTRUCTIONS:



1. Remove protective wrap from gasket.
2. Check to see that the gasket is properly seated, and that the bell and spigot are clean before assembly.
3. Apply the approved lubricant supplied with the pipe to the inside of the bell. The coating should be equivalent to a brush coat of enamel paint.
4. Align pipe and assemble joint together, making sure to keep the proper line and grade.
5. If undue resistance to insertion of the spigot is encountered, or the assembly mark does not reach the flush position, disassemble the joint and check the position of the rubber gasket, and remove any debris.

Please look for this installation instructions sticker on each piece of the Eagle Green PE™ (Dual Wall) pipe.

WARRANTY

JM EAGLE™ PRODUCTS LIMITED WARRANTY

J-M Manufacturing Co., Inc. (JM Eagle™) warrants that its standard polyvinyl chloride (PVC), polyethylene (PE), conduit/plumbing/solvent weld and Acrylonitrile-Butadiene-Styrene (ABS) pipe Products (“Products”) are manufactured in accordance with applicable industry specifications referenced on the Product and are free from defects in workmanship and materials. Every claim under this warranty shall be void unless in writing and received by JM Eagle™ within thirty (30) days of the date the defect was discovered, and within one (1) year of the date of shipment from the JM Eagle™ plant. Claims for Product appearance defects, such as sun-bleached pipe etc., however, must be made within thirty (30) days of the date of the shipment from the JM Eagle™ plant. This warranty specifically excludes any Products allowed to become sun-bleached after shipment from the JM Eagle™ plant. Proof of purchase with the date thereof must be presented to the satisfaction of JM Eagle™, with any claim made pursuant to this warranty. JM Eagle™ must first be given an opportunity to inspect the alleged defective Products in order to determine if it meets applicable industry standards, if the handling and installation have been satisfactorily performed in accordance with JM Eagle™ recommended practices and if operating conditions are within standards. Written permission and/or a Return Goods Authorization (RGA) must be obtained along with instructions for return shipment to JM Eagle™ of any Products claimed to be defective.

The limited and exclusive remedy for breach of this Limited Warranty shall be, at JM Eagle’s sole discretion, the replacement of the same type, size and like quantity of non-defective Product, or credits, offsets, or combination of thereof, for the wholesale purchase price of the defective unit.

This Limited Warranty does not apply for any Product failures caused by user’s flawed designs or specifications, unsatisfactory applications, improper installations, use in conjunction with incompatible materials, contact with aggressive chemical agents, freezing or overheating of liquids in the product and any other misuse causes not listed here. This Limited Warranty also excludes failure or damage caused by fire stopping materials, thread sealants, plasticized vinyl Products or damage caused by the fault or negligence of anyone other than JM Eagle™, or any other act or event beyond the control of JM Eagle™.

JM Eagle’s liability shall not, at any time, exceed the actual wholesale purchase price of the Product. The warranties in this document are the only warranties applicable to the Product and there are no other warranties, expressed or implied. This Limited Warranty specifically excludes any liability for general damages, consequential or incidental damages, including without limitation, costs incurred from removal, reinstallation, or other expenses resulting from any defect. IMPLIED WARRANTIES OF MERCHANTABILITY OR FITNESS FOR A PARTICULAR PURPOSE ARE SPECIFICALLY DISCLAIMED AND JM EAGLE™ SHALL NOT BE LIABLE IN THIS RESPECT NOTWITHSTANDING JM EAGLE’S ACTUAL KNOWLEDGE OF THE PRODUCT’S INTENDED USE.

JM Eagle’s Products should be used in accordance with standards set forth by local plumbing and building laws, codes, or regulations and the applicable standards. Failure to adhere to these standards shall void this Limited Warranty. Products sold by JM Eagle™ that are manufactured by others are warranted only to the extent and limits of the warranty of the manufacturer. No statement, conduct or description by JM Eagle™ or its representative, in addition to or beyond this Limited Warranty, shall constitute a warranty. This Limited Warranty may only be modified in writing signed by an officer of JM Eagle™.



PLANT LOCATIONS

ADEL

2101 J-M Drive
Adel, Georgia 31620

BATCHELOR

2894 Marion Monk Road
Batchelor, Louisiana 70715

BUTNER

2602 West Lyon Station Road
Creedmoor, North Carolina 27522

CAMERON PARK

3500 Robin Lane
Cameron Park, California 95682

COLUMBIA

6500 North Brown Station Road
Columbia, Missouri 65202

CONROE

101 East Avenue M
Conroe, Texas 77301

FONTANA

10990 Hemlock Avenue
Fontana, California 92337

HASTINGS

146 North Maple Avenue
Hastings, Nebraska 68901

KINGMAN

4620 Olympic Way
Kingman, Arizona 86401

MAGNOLIA

2220 Duracrete Drive
Magnolia, Arkansas 71753

MCNARY

31240 Roxbury Road
Umatilla, Oregon 97882

MEADVILLE

15661 Delano Road
Cochranon, Pennsylvania 16314

PERRIS

23711 Rider Street
Perris, California 92570

PUEBLO

1742 E. Platteville Boulevard
Pueblo West, Colorado 81007

STOCKTON

1051 Sperry Road
Stockton, California 95206

SUNNYSIDE

1820 South First Street
Sunnyside, Washington 98944

TACOMA

2330 Port of Tacoma Road
Tacoma, Washington 98421

TULSA

4501 West 49th Street
Tulsa, Oklahoma 74107

VISALIA

8875 Avenue 304
Visalia, California 93291

WHARTON

10807 US 59 RD
Wharton, Texas 77488

WILTON

1314 W. Third Street
Wilton, Iowa 52778

MEXICO

PLASTICS TECHNOLOGY
DE MÉXICO S DE R.L. DE S.A.
Av. Montes Urales No. 8 y 10
Parque Industrial Opción, Carretera
57 Qro. -S.L.P. Km. 57.8
C.P. 37980 San José Iturbide,
Guanajuato México

** Our Mexico location is a joint
venture between JM Eagle™ and
Plastics Technology*

GLOBAL HEADQUARTERS

5200 West Century Boulevard
Los Angeles, California 90045

REGIONAL OFFICE

Nine Peach Tree Hill Road
Livingston, New Jersey 07039

J-M Manufacturing Co., Inc. and PW Eagle, Inc. are doing business as JM Eagle™.

JM Eagle

- THE LEADER IN PIPE INNOVATION
- THE HIGHEST LEVEL OF QUALITY
- THE LARGEST BREADTH OF PRODUCT
- THE WIDEST CAPACITY
- EXPRESS DELIVERY



PLANT LOCATIONS

February 2012

JME-18A

© J-M Manufacturing Co., Inc.



*Building essentials
for a better tomorrow™*

GLOBAL HEADQUARTERS:

5200 West Century Blvd
Los Angeles, CA 90045
T: 800.621.4404
F: 800.451.4170

www.JMEagle.com

Nine Peach Tree Hill Road
Livingston, NJ 07039
T: 973.535.1633
F: 973.533.4185

This information may have been updated. Download the latest version at www.jmeagle.com.